



RF-TI1352P2 CC1352P7 SimpleLink™ High- Performance Sub-1G + 2.4 G Multi-band Module With Integrated Power Amplifier

Version 1.0

Shenzhen RF-star Technology Co., Ltd.

Oct. 31th, 2023

All rights reserved. Those responsible for unauthorized reproduction will be prosecuted.

1 Device Overview

1.1 Description

RF-TI1352P2 is an RF module based on TI SoC CC1352P7 with an integrated power amplifier. It integrates a 48 MHz and a 32.768 kHz crystal, a 256 KB ROM, a 704 KB Flash, and the IPEX connectors and half-hole RF output pins of different radio frequency to guarantee the external antenna connection. Its ARM® Cortex®-M4F core application processor optimized for long-range and low-power. It features small size, robust connection distance, and rigid reliability. The multi-band module supporting multiprotocol for both Sub-1 GHz and 2.4 GHz through a DMM driver for Thread, Zigbee®, Matter, Bluetooth® 5.3 Low Energy, IEEE 802.15.4g, IPv6-enabled smart objects (6LoWPAN), MIOTY®, proprietary systems, including the TI 15.4-Stack (Sub-1 GHz and 2.4 GHz). 1.27-mm pitch stamp stick package for easy assembling and cost-effective PCB design.

1.2 Key Features

- RF Section
 - Bluetooth 5.2 Low Energy
 - ZigBee, Thread, Matter
 - IEEE 802.15.4
 - IPv6-enabled smart objects (6LoWPAN)
 - MIOTY®
 - Wireless M-Bus
 - Wi-SUN®
 - KNX RF
 - Amazon Sidewalk
 - Proprietary systems
 - SimpleLink™ TI 15.4-Stack (Sub-1 GHz)
 - Dynamic Multiprotocol Manager (DDM) driver
- TX power:
 - Up to +20 dBm (Sub-1 GHz) with temperature compensation
 - Up to +5 dBm (2.4 GHz) with temperature compensation
- Excellent receiver sensitivity
 - -121 dBm @ Sub-1 GHz (SimpleLink Long-range Mode)
 - -110 dBm @ Sub-1 GHz (50 kbps)
- -104 dBm for Bluetooth 125 kbps (LE coded PHY)
- Wide Operation Range
 - 1.8 V to 3.8 V single power supply
 - Operating temperature: -40 °C to +85 °C
 - Storage temperature: -40 °C to +125 °C
- Microcontroller
 - Powerful 48 MHz ARM® Cortex®-M4F processor
 - 2-pin cJTAG and JTAG debugging
 - Supports OTA upgrade
- Memory
 - 704 KB of in-system programmable flash
 - 256 KB of ROM for protocols and library functions
 - 8 KB of Cache SRAM
 - 80 KB of ultra-low leakage SRAM
- Ultra-low power sensor controller with 4KB of SRAM
 - Sample, store, and process sensor data
 - Operation independent from system CPU
 - Fast wake-up for low-power operation
- Rich Peripherals

- 24 GPIOs, digital peripherals can be routed to any GPIOs
- 4× 32-bit or 8× 16-bit general-purpose timers
- 12-bit ADC, 200 kSamples/s, 8 channels
- 2 × comparators with internal reference DAC (1 × continuous time, 1 × ultra-low power)
- Programmable current source
- 2 × UART
- 2 × SSI (SPI, MICROWIRE, TI)
- I²C
- I²S
- Real-time clock (RTC)
- Capacitive sensing, up to 8 channels
- Integrated temperature and battery monitor
- Security Enablers
 - AES 128-bit and 256-bit Crypto accelerator
 - ECC and RSA public key hardware accelerator
 - SHA2 accelerator (full suite up to SHA-512)
 - True random number generator (TRNG)
- External system
 - On-chip buck DC/DC converter
 - TCXO support
- Dimension: 26.9 mm × 16.9 mm × 2.1 mm

1.3 Applications

- Building security systems – motion detector, electronic smart lock, door and window sensor, garage door system, gateway
- HVAC – thermostat, wireless environmental sensor, HVAC system controller, gateway
- Fire safety system – smoke and heat detector, fire alarm control panel (FACP)
- Video surveillance – IP network camera
- Elevators and escalators – elevator main control panel for elevators and escalators
- Smart meters – water meter, gas meter, electricity meter, and heat cost allocators
- Grid communications – wireless communications – Long-range sensor applications
- Other alternative energy – energy harvesting
- Industrial transport – asset tracking
- Factory automation and control
- Medical
- Electronic point of sale (EPOS) – Electronic Shelf Label (ESL)
- Wired networking – wireless LAN or Wi-Fi access points, edge router
- Portable electronics – RF smart remote control
- Home theater & entertainment – smart speakers, smart display, set-top box
- Connected peripherals – consumer wireless module, pointing devices, keyboards and keypads
- Gaming – electronic and robotic toys
- Wearables (non-medical) – smart trackers, smart clothing

1.4 Functional Block Diagram

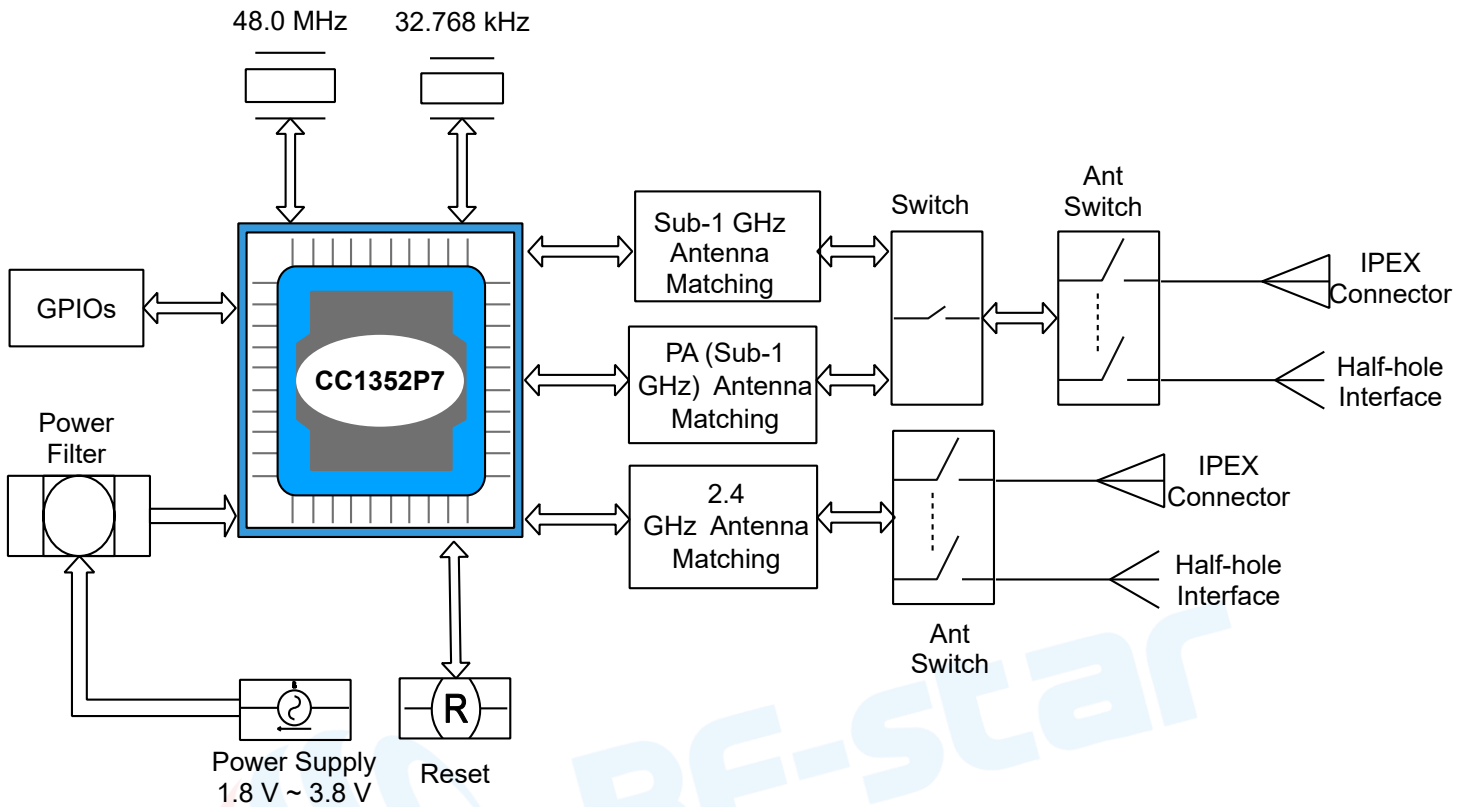

Figure 1. Functional Block Diagram of RF-TI1352P2

1.5 Part Number Conventions

The part numbers are of the form of RF-TI1352P2 where the fields are defined as follows:

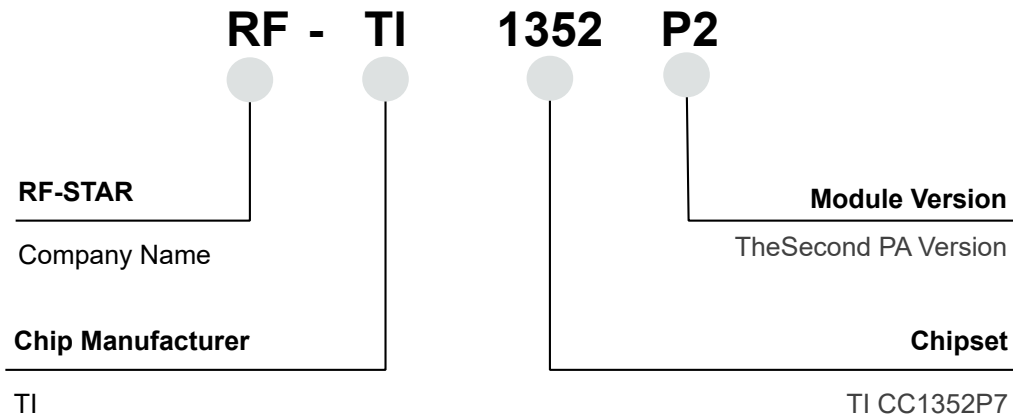

Figure 2. Part Number Conventions of RF-TI1352P2

Table of Contents

1 Device Overview	1
1.1 Description.....	1
1.2 Key Features	1
1.3 Applications.....	2
1.4 Functional Block Diagram	3
1.5 Part Number Conventions	3
Table of Contents.....	4
2 Module Configuration and Functions	6
2.1 Module Parameters.....	6
2.2 Module Pin Diagram	7
3.3 Pin Functions.....	8
3 Specifications	10
3.1 Recommended Operating Conditions	10
3.2 Handling Ratings.....	10
3.3 PA Output Control	10
4 Application, Implementation, and Layout.....	11
4.1 Module Photos.....	11
4.2 Recommended PCB Footprint.....	11
4.3 Schematic Diagram.....	12
4.4 Antenna.....	12
4.4.1 Antenna Design Recommendation	12
4.4.2 Antenna Output Mode Modification.....	13
4.4.3 External Antenna Design Recommendation of the Half-Hole ANT Pin.....	13
4.4.4 IPEX Connector Specification	15
4.5 Basic Operation of Hardware Design	15
4.6 Trouble Shooting.....	16
4.6.1 Unsatisfactory Transmission Distance.....	16
4.6.2 Vulnerable Module.....	17
4.6.3 High Bit Error Rate	17
4.7 Electrostatics Discharge Warnings	17
4.8 Soldering and Reflow Condition.....	17

5 Optional Package Specification	19
6 Revision History	21
7 Contact Us.....	22



2 Module Configuration and Functions

2.1 Module Parameters

Table 1. Parameters of RF-TI1352P2

Chipset	CC1352P7
Supply Power Voltage	1.8 V ~ 3.8 V, 3.3 V is recommended
Frequency	800 MHz ~ 928 MHz, 2402 MHz ~ 2480 MHz
Maximum Transmit Power	+20.0 dBm (Sub-1 GHz) +5 dBm (2.4 GHz)
Receiving Sensitivity	-121 dBm @ Sub-1 GHz (Long-range Mode) -110 dBm @ Sub-1 GHz (50 kbps) -104 dBm @ Sub-1 GHz (100 kbps) -97 dBm @ Bluetooth 5.0 (1 Mbps) -92 dBm @ Bluetooth 5.0 (2 Mbps) -104 dBm @ Bluetooth 5.0 (125 kbps LE Coded PHY)
GPIO	24
Flash	704 KB
ROM	256 KB
SRAM	88 KB
Power Consumption	RX current: 5.8 mA @3.6 V, 868 MHz 6.9 mA @3.0 V, 2.4 GHz TX current: 63.0 mA @ +20 dBm, 3.3 V, 915 MHz 85.0 mA @ +20 dBm, 3.0 V, 2.4 GHz 22.0 mA @ +10 dBm, 2.4 GHz MCU 48 MHz (CoreMark): 2.9 mA (60 μ A/MHz) Sensor Controller: 30.1 μ A @ low power mode, 2 MHz, running infinite loop 808 μ A @ active mode, 24 MHz, running infinite loop Standby mode: 0.85 μ A Sleep Mode: 150 nA
Support Protocol	Thread, Zigbee®, Matter, Bluetooth® 5.3 Low Energy, IEEE 802.15.4g, IPv6-enabled smart objects, (6LoWPAN), MIOTY®, Wireless M-Bus, Wi-SUN®, KNX RF, Amazon Sidewalk, proprietary systems, SimpleLink™ TI 15.4-Stack (Sub-1 GHz)

Crystal	48 MHz, 32.768 kHz
Package	SMT packaging (1.27-mm half-hole pitch stamp stick)
Dimension	26.5 mm × 16.9 mm × 2.1 mm
Type of Antenna	Half-hole ANT interface, IPEX connector
Operating Temperature	-40 °C ~ +85 °C
Storage Temperature	-40 °C ~ +125 °C

2.2 Module Pin Diagram

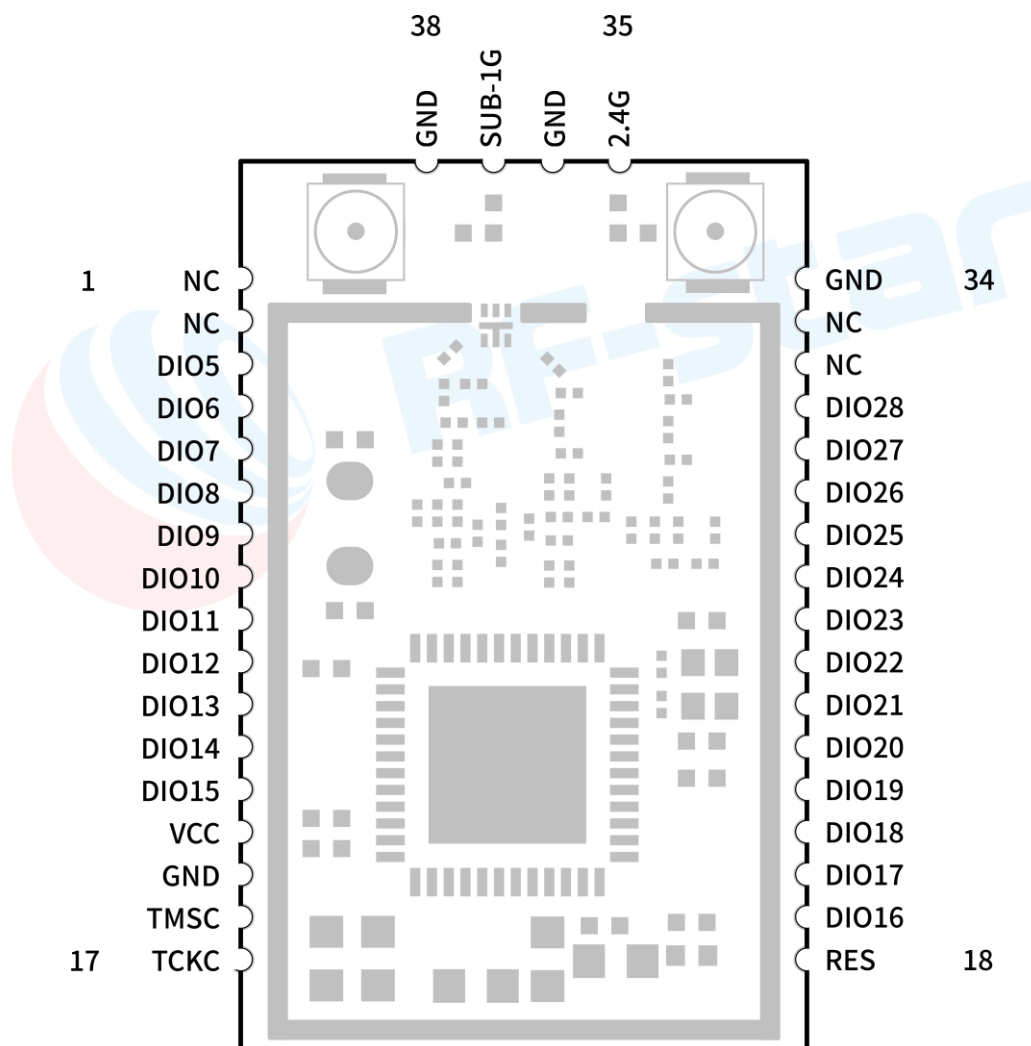

Figure 3. Pin Diagram of RF-TI1352P2

3.3 Pin Functions

Table 2. Pin Functions of RF-TI1352P2

Pin	Name	Chip Pin	Function	Description
1	NC	-	-	None connect
2	NC	-	-	-None connect
3	DIO5	DIO_5	Digital	GPIO, high-drive capability
4	DIO6	DIO_6	Digital	GPIO, high-drive capability
5	DIO7	DIO_7	Digital	GPIO, high-drive capability
6	DIO8	DIO_8	Digital	GPIO
7	DIO9	DIO_9	Digital	GPIO
8	DIO10	DIO_10	Digital	GPIO
9	DIO11	DIO_11	Digital	GPIO
10	DIO12	DIO_12	Digital	GPIO
11	DIO13	DIO_13	Digital	GPIO
12	DIO14	DIO_14	Digital	GPIO
13	DIO15	DIO_15	Digital	GPIO
14	VDD	VDDS	VDD	Power Supply: 1.8 V ~ 3.8 V, recommend to 3.3 V
15	GND	GND	GND	Ground
16	TMSC	JTAG_TMSC	Digital	JTAG TMSC, high-drive capability
17	TCKC	JTAG_TCKC	Digital	JTAG TCKC
18	RES	RESET_N	Digital	Reset, active low. Internal pullup.
19	DIO16	DIO_16	Digital	GPIO, JTAG_TDO, high-drive capability
20	DIO17	DIO_17	Digital	GPIO, JTAG_TDI, high-drive capability
21	DIO18	DIO_18	Digital	GPIO
22	DIO19	DIO_19	Digital	GPIO
23	DIO20	DIO_20	Digital	GPIO
24	DIO21	DIO_21	Digital	GPIO

25	DIO22	DIO_22	Digital	GPIO
26	DIO23	DIO_23	Digital or Analog	GPIO, analog capability
27	DIO24	DIO_24	Digital or Analog	GPIO, analog capability
28	DIO25	DIO_25	Digital or Analog	GPIO, analog capability
29	DIO26	DIO_26	Digital or Analog	GPIO, analog capability
30	DIO27	DIO_27	Digital or Analog	GPIO, analog capability
31	DIO28	DIO_28	Digital or Analog	GPIO, analog capability
32	NC	-	-	None connect
33	NC	-	-	None connect
34	GND	GND	Ground	Ground
35	2G4-OUT		RF Out	2.4 GHz antenna pinout
36	GND	GND	Antenna Ground	Antenna Ground
37	SUB-OUT		RF Out	Sub 1GHz antenna pinout
38	GND	GND	Ground	Ground

3 Specifications

3.1 Recommended Operating Conditions

Functional operation does not guarantee performance beyond the limits of the conditional parameter values in the table below. Long-term work beyond this limit will affect the reliability of the module more or less.

Table 3. Recommended Operating Conditions of RF-TI1352P2

Items	Condition	Min.	Typ.	Max.	Unit
Operating Supply Voltage	/	1.8	3.3	3.8	V
Operating Temperature	/	-40	+25	+85	°C

3.2 Handling Ratings

Table 4. Handling Ratings of RF-TI1352P2

Items	Condition	Min.	Typ.	Max.	Unit
Storage Temperature	Tstg	-40	+25	+125	°C
Human Body Model	HBM		±2000		V
Moisture Sensitivity Level			3		
Charged Device Model			±500		V

3.3 PA Output Control

The Sub-1 GHz PA of the CC1352P7 switches the RF switch by controlling the output of DIO29 and DIO30, and then switches the PA and non-PA RF output to realize the control of the transmission power range.

Table 3. RF Control Truth Table

Power	DIO29 (Output)	DIO30 (Output)
+5 dBm ~ + 20 dBm (PA)	1	0
< 5 dBm	0	1

4 Application, Implementation, and Layout

4.1 Module Photos

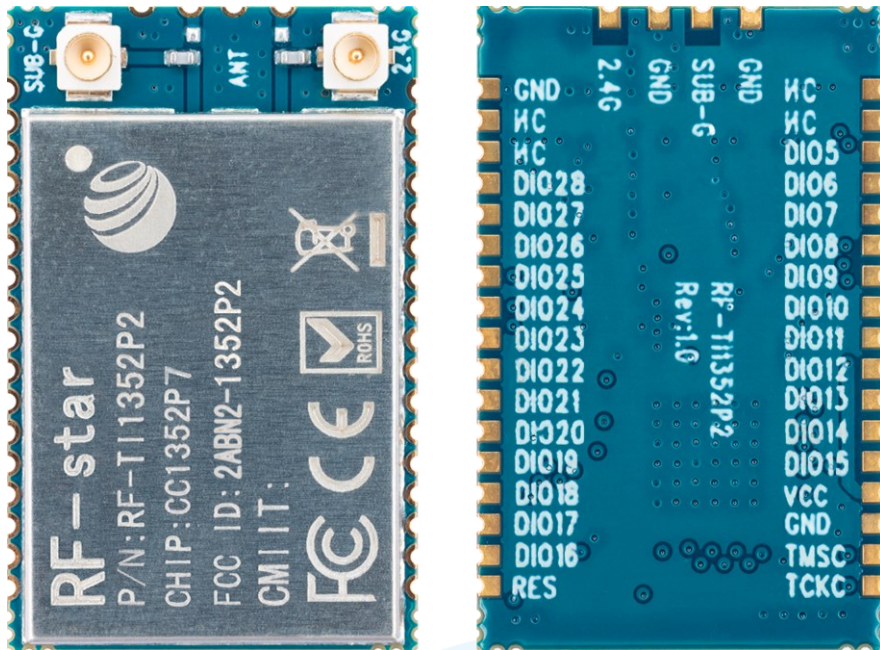
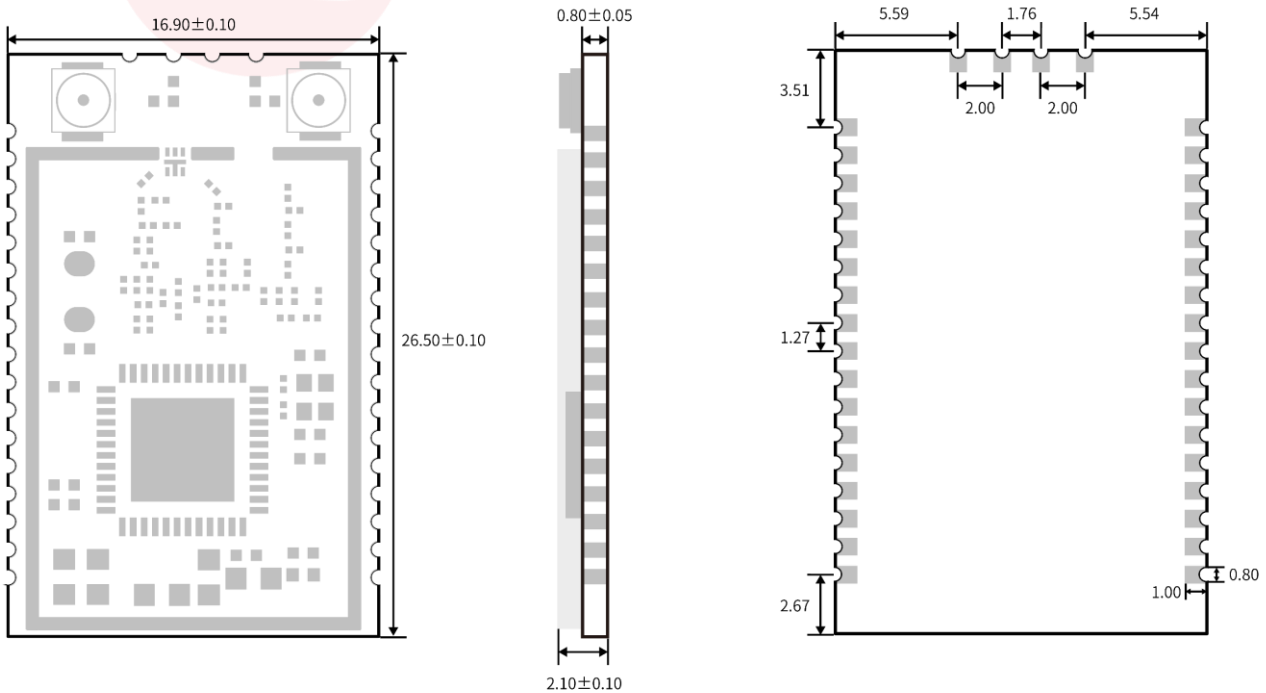

Figure 4. Photos of RF-TI1352P2

4.2 Recommended PCB Footprint



UNIT:mm

Figure 5. Recommended PCB Footprint of RF-TI1352P2

- (1) Place the antenna on the edge (corner) of the PCB.
- (2) Make sure that there is no signal line or copper foil in each layer below the antenna.
- (3) It is best to hollow out the antenna position in the following figure to ensure that the S11 of the module is minimally affected.

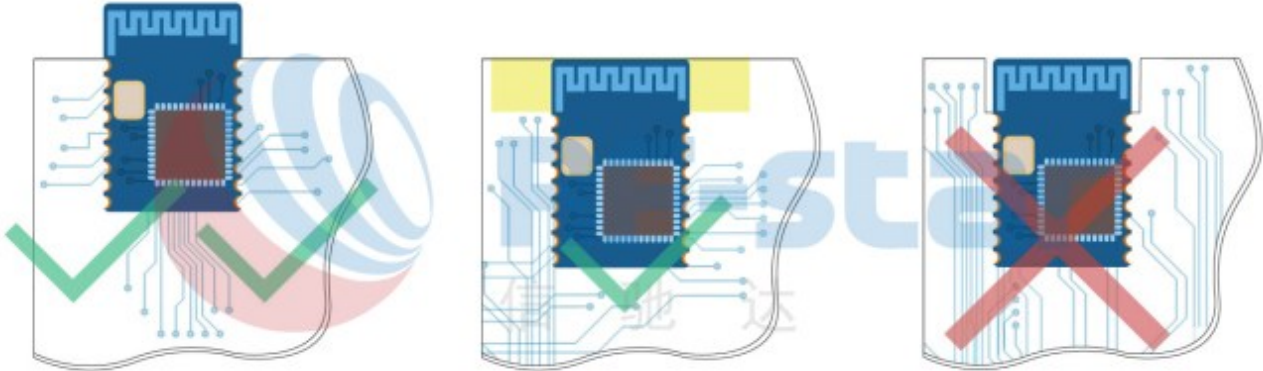

Figure 7. Recommendation of Antenna Layout

Note: The hollow-out position is based on the antenna used.

4.4.2 Antenna Output Mode Modification

1. The module has two antenna output modes: IPEX connector and half-hole ANT pin. The default RF is IPEX connector, if the ANT pin antenna output mode needs to be used, please conduct according to the following steps. Move the component in the red circle to the green circle, vice versa. The left is for Sub-1 GHz and the right is for 2.4 GHz.



Figure 8. Antenna Output Mode Modification of RF-TI1352P2

4.4.3 External Antenna Design Recommendation of the Half-Hole ANT Pin

1. A Π -type matching circuit is reserved for the antenna, and $50\ \Omega$ impedance control is performed on the RF traces. The traces are as short as possible, and 135° or arc traces are used as much as possible. No vias are used to

change layers. More GND vias are placed around the RF traces.

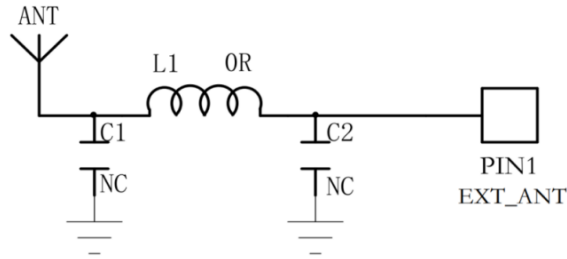

Figure 9. Reference Design of the External Antenna

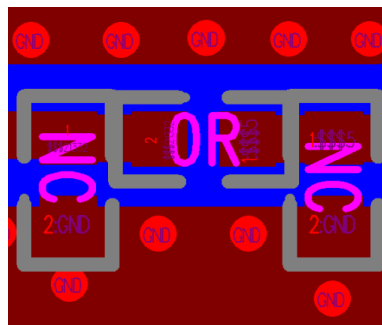

Figure 10. Reference Design of the External Antenna Traces

2. The RF trace width and copper-clad spacing can be calculated by SI9000 software, and the impedance is controlled to 50Ω according to the actual board thickness, number of layers, plate, dielectric thickness, dielectric constant, copper thickness, line width, line spacing, and solder mask thickness.

Example: FR4 is a double-layer board with a thickness of 1.0 mm. Through calculation, the width of the trace is 0.8254 mm, and the spacing between traces and copper is 0.22 mm.

Parameter	Value	Tolerance	Minimum	Maximum	Action
Substrate 1 Height	H1	0.8800 +/-	0.8800	0.8800	Calculate
Substrate 1 Dielectric	Er1	4.4000 +/-	4.4000	4.4000	Calculate
Lower Trace Width	W1	0.8254 +/-	0.8254	0.8254	Calculate
Upper Trace Width	W2	0.8000 +/-	0.8000	0.8000	Calculate
Ground Strip Separation	D1	0.2200 +/-	0.2200	0.2200	Calculate
Trace Thickness	T1	0.0350 +/-	0.0350	0.0350	Calculate
Coating Above Substrate	C1	0.0254 +/-	0.0254	0.0254	Calculate
Coating Above Trace	C2	0.0254 +/-	0.0254	0.0254	Calculate
Coating Dielectric	CEr	4.2000 +/-	4.2000	4.2000	Calculate
Impedance	Zo	50.10	50.10	50.10	Calculate

Figure 11. SI9000 Impedance Calculation Diagram

4.4.4 IPEX Connector Specification

RF-TI1352P2 module is integrated the IPEX version 1 antenna seat, the specification of the antenna seat is as follows:

Figure 12. Specification of Antenna Seat

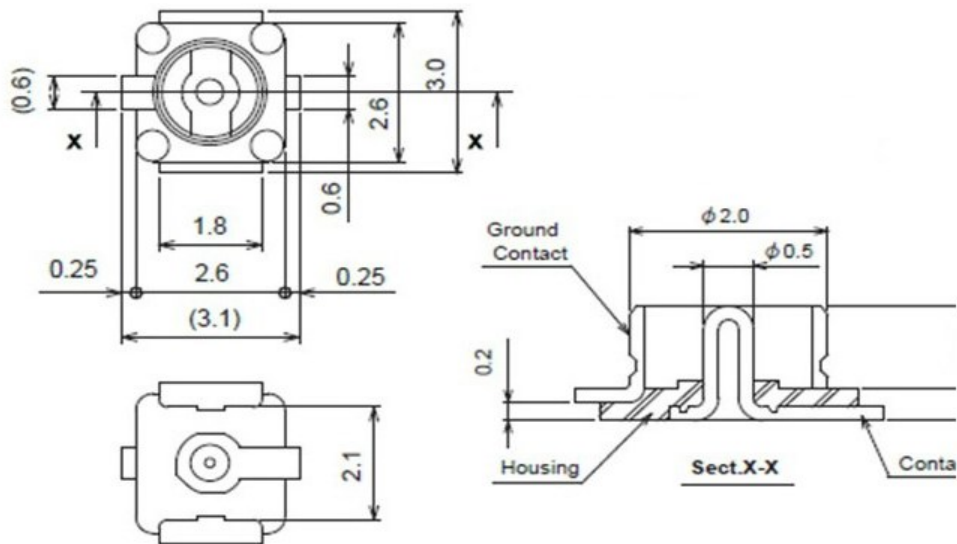

The specification of the IPEX wire end is as follows:

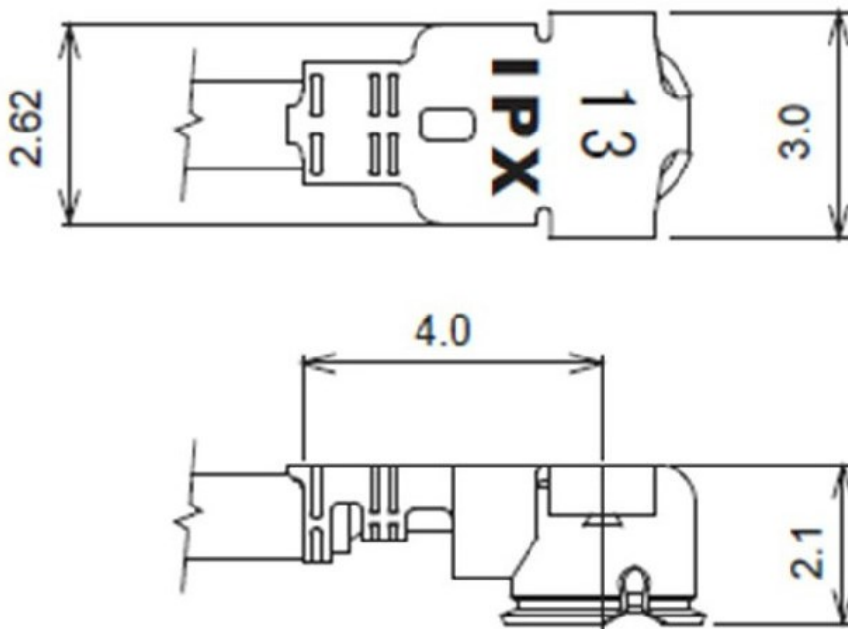

Figure 13. Specification of IPEX Wire

4.5 Basic Operation of Hardware Design

1. It is recommended to offer the module a DC stabilized power supply, a tiny power supply ripple coefficient, and reliable ground. Please pay attention to the correct connection between the positive and negative poles of the power

supply. Otherwise, the reverse connection may cause permanent damage to the module.

2. Please ensure the supply voltage is between the recommended values. The module will be permanently damaged if the voltage exceeds the maximum value. Please ensure a stable power supply and no frequently fluctuating voltage.
3. When designing the power supply circuit for the module, it is recommended to reserve more than 30% of the margin, which is beneficial to the long-term stable operation of the whole machine. The module should be far away from the power electromagnetic, transformer, high-frequency wiring, and other parts with large electromagnetic interference.
4. The bottom of the module should avoid high-frequency digital routing, high-frequency analog routing, and power routing. If it has to route the wire on the bottom of the module, for example, it is assumed that the module is soldered to the Top Layer, the copper must be spread on the connection part of the top layer and the module, and be close to the digital part of the module and routed in the Bottom Layer (all copper is well-grounded).
5. Assuming that the module is soldered or placed in the Top Layer, it is also wrong to randomly route the Bottom Layer or other layers, which will affect the spurs and receiving sensitivity of the module to some degree.
6. Assuming that there are devices with large electromagnetic interference around the module, which will greatly affect the module performance. It is recommended to stay away from the module according to the strength of the interference. If circumstances permit, appropriate isolation and shielding can be done.
7. Assuming that there are routings of large electromagnetic interference around the module (high-frequency digital, high-frequency analog, power routings), which will also greatly affect the module performance. It is recommended to stay away from the module according to the strength of the interference. If circumstances permit, appropriate isolation and shielding can be done.
8. It is recommended to stay away from the devices whose TTL protocol is the same Sub-1 GHz and 2.4 GHz physical layer, for example, USB 3.0.

4.6 Trouble Shooting

4.6.1 Unsatisfactory Transmission Distance

1. When there is a linear communication obstacle, the communication distance will be correspondingly weakened. Temperature, humidity, and co-channel interference will lead to an increase in the communication packet loss rate. The performances of ground absorption and reflection of radio waves will be poor when the module is tested close to the ground.
2. Seawater has a strong ability to absorb radio waves, so the test results by the seaside are poor.
3. The signal attenuation will be very obvious if there is metal near the antenna or if the module is placed inside the metal shell.
4. The incorrect power register set or the high data rate in the open air may shorten the communication distance. The higher the data rate, the closer the distance.

5. The low voltage of the power supply is lower than the recommended value at ambient temperature, and the lower the voltage, the smaller the power is.
6. The unmatchable antennas and modules or the poor quality of antenna will affect the communication distance.

4.6.2 Vulnerable Module

1. Please ensure the supply voltage is between the recommended values. The module will be permanently damaged if the voltage exceeds the maximum value. Please ensure a stable power supply and no frequently fluctuating voltage.
2. Please ensure the anti-static installation and the electrostatic sensitivity of high-frequency devices.
3. Due to some humidity-sensitive components, please ensure the suitable humidity during installation and application. If there is no special demand, it is not recommended to use at too high or too low temperature.

4.6.3 High Bit Error Rate

1. There are co-channel signal interferences nearby. It is recommended to be away from the interference sources or modify the frequency and channel to avoid interferences.
2. The unsatisfactory power supply may also cause garbled. It is necessary to ensure the power supply's reliability.
3. If the extension wire or feeder wire is of poor quality or too long, the bit error rate will be high.

4.7 Electrostatics Discharge Warnings

The module will be damaged by the discharge of static. RF-star suggests that all modules should follow the 3 precautions below:

1. According to the anti-static measures, bare hands are not allowed to touch modules.
2. Modules must be placed in anti-static areas.
3. Take the anti-static circuitry (when inputting HV or VHF) into consideration in product design.
Static may result in the degradation in performance of the module, even causing failure.

4.8 Soldering and Reflow Condition

1. Heating method: Conventional Convection or IR/convection.
2. Solder paste composition: Sn96.5/Ag3.0/Cu0.5
3. Allowable reflow soldering times: 2 times based on the following reflow soldering profile.
4. Temperature profile: Reflow soldering shall be done according to the following temperature profile.
5. Peak temperature: 245 °C.

Table 5. Temperature Table of Soldering and Reflow

Profile Feature	Sn-Pb Assembly	Pb-Free Assembly
Solder Paste	Sn63 / Pb37	Sn96.5 / Ag3.0 / Cu0.5
Min. Preheating Temperature (T_{min})	100 °C	150 °C
Max. Preheating Temperature (T_{max})	150 °C	200 °C
Preheating Time (T_{min} to T_{max}) (t_1)	60 s ~ 120 s	60 s ~ 120 s
Average Ascend Rate (T_{max} to T_p)	Max. 3 °C/s	Max. 3 °C/s
Liquid Temperature (T_L)	183 °C	217 °C
Time above Liquidus (t_L)	60 s ~ 90 s	30 s ~ 90 s
Peak Temperature (T_p)	220 °C ~ 235 °C	230 °C ~ 250 °C
Average Descend Rate (T_p to T_{max})	Max. 6 °C/s	Max. 6 °C/s
Time from 25 °C to Peak Temperature (t_2)	Max. 6 minutes	Max. 8 minutes
Time of Soldering Zone (t_p)	20±10 s	20±10 s

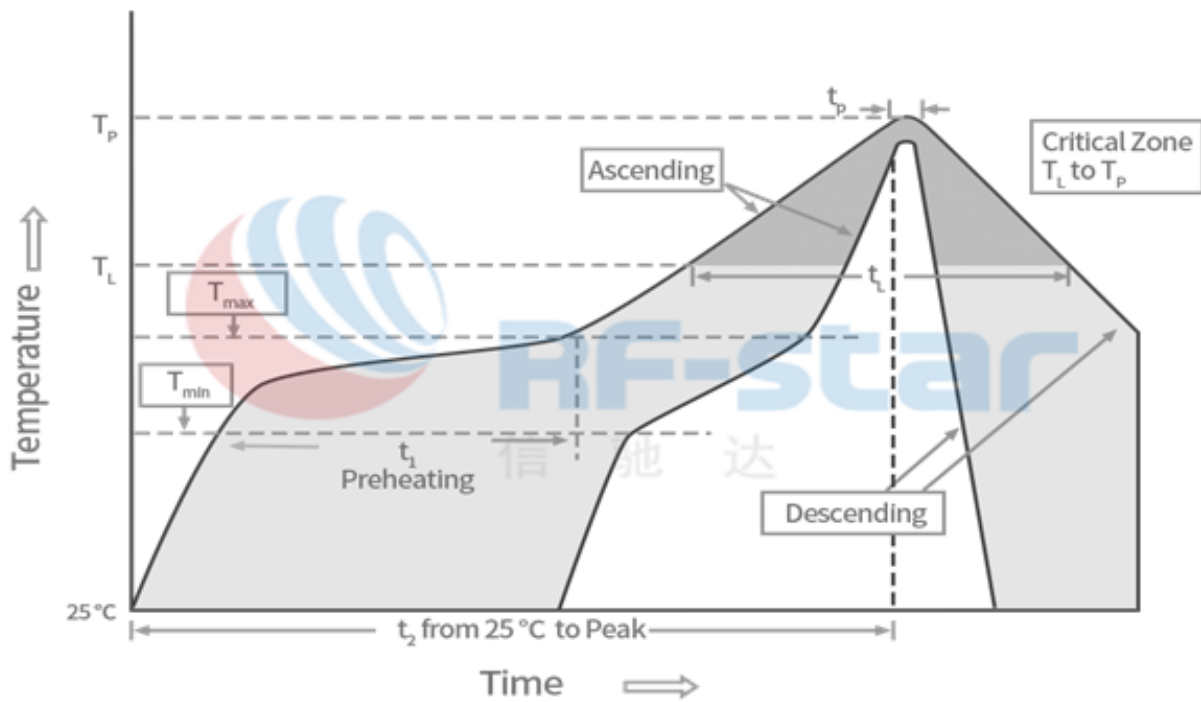

Figure 14. Recommended Reflow for Lead-Free Solder

5 Optional Package Specification

The default package method is **by tray**. If you need the modules to be shipped by tape & reel, pls contact us in advance.

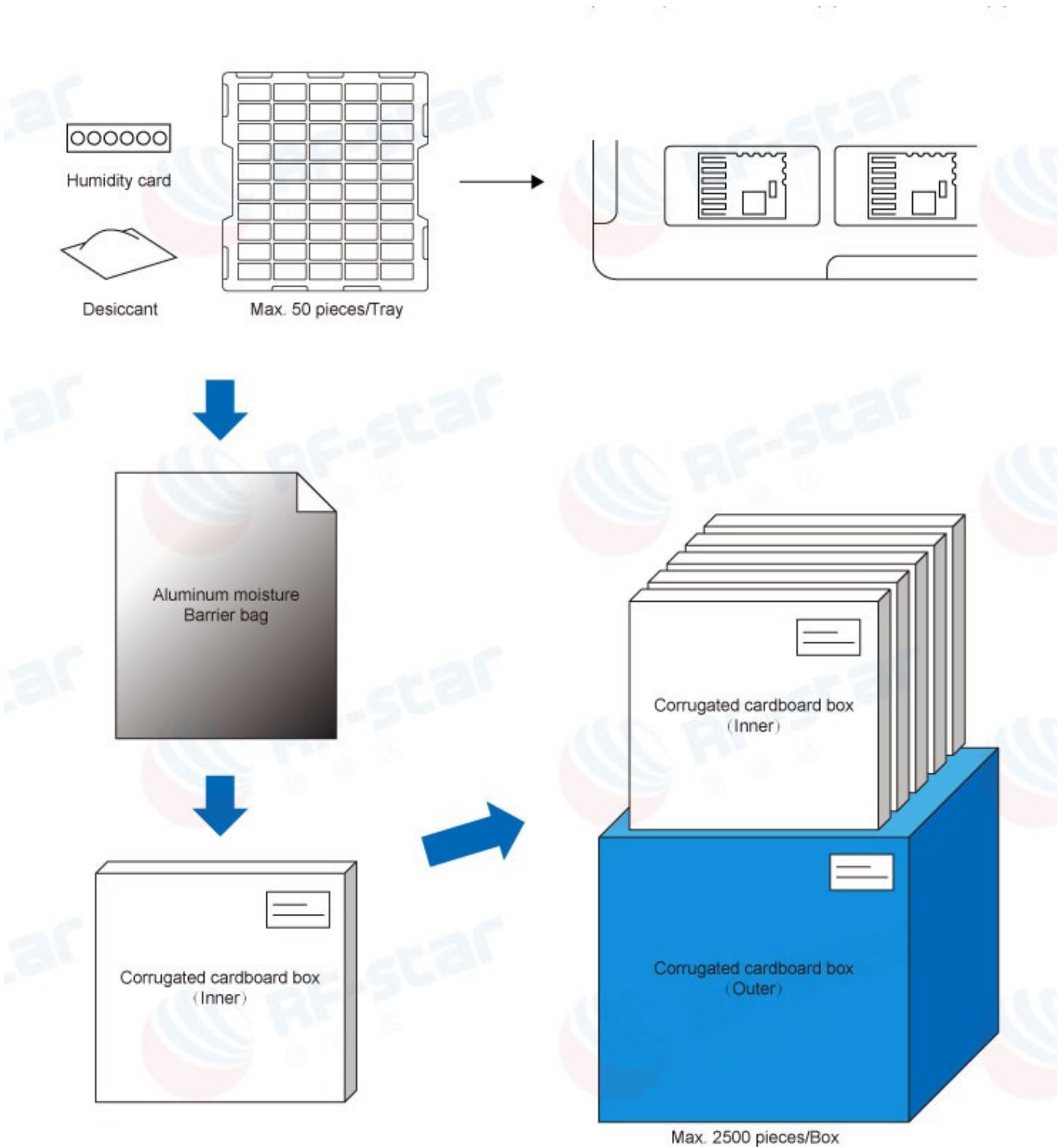

Figure 15. Default Package by Tray

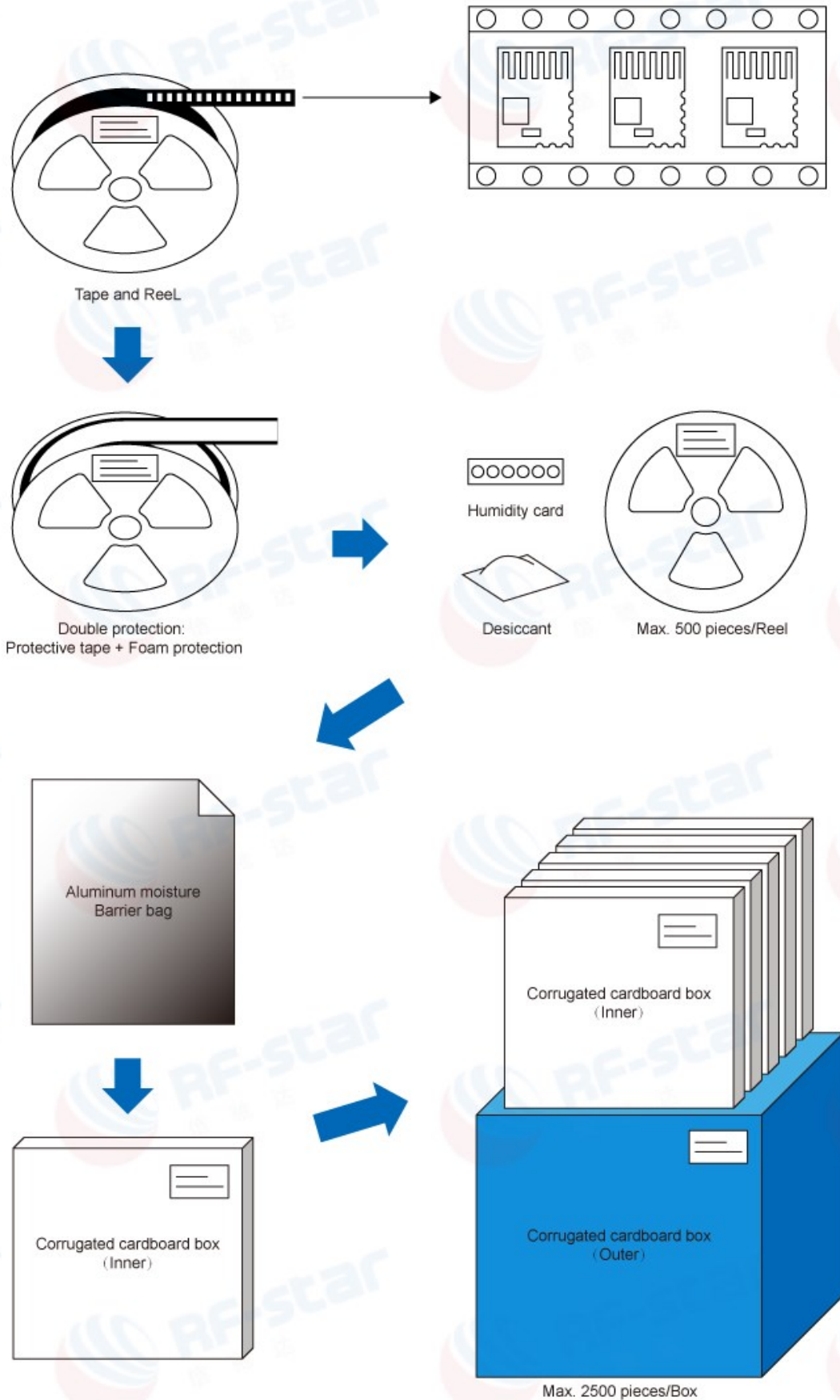

Figure 16. Package by Tape & Reel

6 Revision History

Date	Version No.	Description
2023.09.05	V1.0	The Initial version is released.
2023.10.31	V1.0	Update the pin definition.

Note:

1. The document will be optimized and updated from time to time. Before using this document, please make sure it is the latest version.
2. To obtain the latest document, please download it from the official website: www.rfstariot.com and www.szrfstar.com.



7 Contact Us

SHENZHEN RF-STAR TECHNOLOGY CO., LTD.

Shenzhen HQ:

Add.: Room A502 ~ A503, Podium Building No. 12, Shenzhen Bay Science and Technology Ecological Park, Nanshan District, Shenzhen, Guangdong, China, 518063

Tel.: 86-755-8632 9829

Chengdu Branch:

Add.: N2-1604, Global Center, North No. 1700, Tianfu Avenue, Hi-Tech District, Chengdu, Sichuan, China, 610095

Tel.: 86-28-8692 5399

Email: sunny@szrfstar.com, sales@szrfstar.com

Web.: www.rfstariot.com, www.szrfstar.com

