



RF-BM-ND08C nRF52810

Bluetooth 5.0 Low Energy Module

Version 1.3

Shenzhen RF-star Technology Co., Ltd.

July 24th, 2023

All rights reserved. Those responsible for unauthorized reproduction will be prosecuted.

1 Device Overview

1.1 Description

RF-BM-ND08C is an RF module based on Nordic BLE SoC nRF52810QFAA with ARM® Cortex®-M4 32-bit processor. It integrates a 32.768 kHz and a 32 MHz crystal, an LC filter, an antenna matching and antenna options of a meander line inverted-F PCB antenna and a half-hole interface. It supports Bluetooth 5.0 LE, including the high-speed 2 Mbps feature and ANT and 2.4 GHz proprietary protocols for simple programming. The module has numerous digital peripherals and interfaces such as PDM, PWM, UART, SPI, I²C and 12-bit ADC. It features low power consumption, small size, robust connection distance, and rigid reliability. 1.27-mm pitch stamp stick package for easy assembling and cost-effective PCB design. RF-BM-ND08C is pin-to-pin compatible with RF-BM-ND08.

1.2 Key Features

- RF Features
 - Bluetooth 5.0 low energy
 - ANT
 - 2.4 GHz proprietary
- TX power: -20 to +4 dBm
- ARM® Cortex®-M4 32-bit processor, 64 MHz
- Supply voltage range 1.7 V ~ 3.6 V
- Memory
 - 192 KB flash
 - 24 KB RAM
- Support for concurrent multi-protocol
- Peripherals
 - 12-bit, 200 ksps ADC
 - 16 GPIOs
 - 4-channel PWM
 - Digital microphone interface (PDM)
 - SPI master/slave
 - I²C master/slave
 - UART (CTS/RTS)
- Programmable peripheral interconnect (PPI)
- Quadrature decoder (QDEC)
- AES HW encryption
- Dimension: 15.2 mm x 11.2 mm x 1.7 mm
- Certificate: SRRC

1.3 Applications

- Mouse and keyboard
- Mobile HID
- Remote controls
- Wearables
- Virtual reality headsets
- Health and medical
- Industrial lighting
- Retail
- Commercial
- Beacons

1.4 Functional Block Diagram

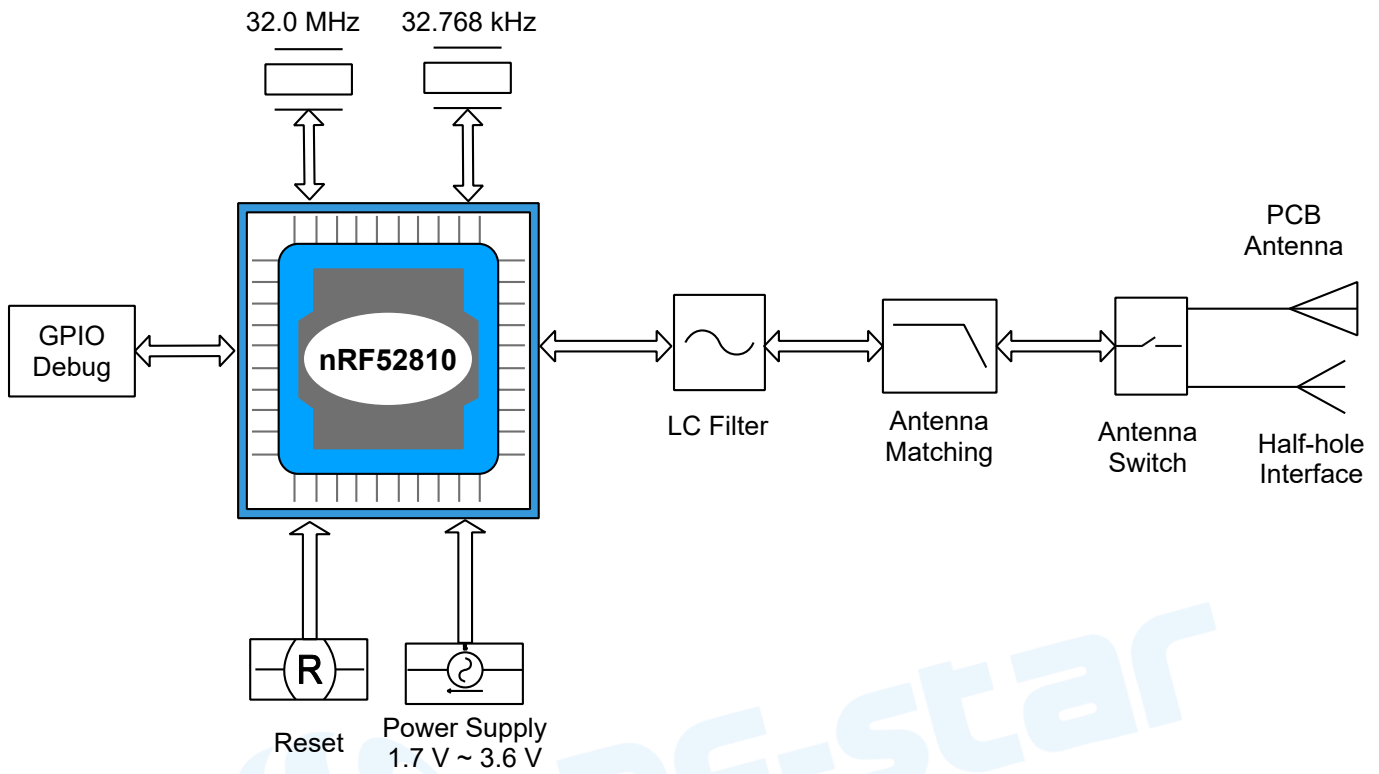

Figure 1. Functional Block Diagram of RF-BM-ND08C

1.5 Part Number Conventions

The part numbers are of the form of RF-BM-ND08C where the fields are defined as follows:

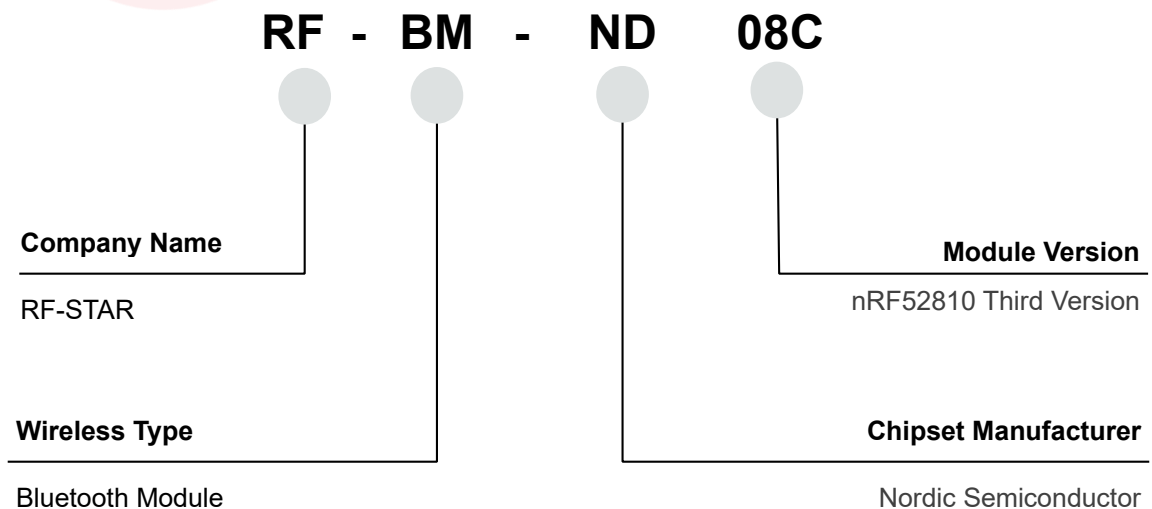

Figure 2. Part Number Conventions of RF-BM-ND08C

Table of Contents

1 Device Overview	1
1.1 Description.....	1
1.2 Key Features	1
1.3 Applications	1
1.4 Functional Block Diagram	2
1.5 Part Number Conventions	2
Table of Contents.....	3
2 Module Configuration and Functions	5
2.1 Module Parameters.....	5
2.2 Module Pin Diagram	6
2.3 Pin Functions.....	6
3 Specifications	8
3.1 Recommended Operating Conditions	8
3.2 Handling Ratings.....	8
3.3 Power Consumption	8
4 Application, Implementation, and Layout.....	9
4.1 Module Photos	9
4.2 Recommended PCB Footprint.....	9
4.3 Schematic Diagram.....	10
4.4 Reference Design	10
4.5 Antenna.....	11
4.5.1 Antenna Design Recommendation	11
4.5.2 Antenna Output Mode Modification.....	11
4.5.3 External Antenna Design Recommendation of the Half-Hole ANT Pin.....	12
4.6 Basic Operation of Hardware Design	13
4.7 Trouble Shooting	14
4.7.1 Unsatisfactory Transmission Distance.....	14
4.7.2 Vulnerable Module.....	14
4.7.3 High Bit Error Rate	14
4.8 Electrostatics Discharge Warnings	14
4.9 Soldering and Reflow Condition.....	15
5 Optional Package Specification	17

6 Certification	19
6.1 SRRC	19
7 Revision History	20
8 Contact Us	21



2 Module Configuration and Functions

2.1 Module Parameters

Table 1. Parameters of RF-BM-ND08C

Chipset	nRF52810
Supply Power Voltage	1.7 V ~ 3.6 V, recommended to 3.3 V
Frequency	2402 MHz ~ 2480 MHz
Transmit Power	-20.0 dBm ~ +4.0 dBm (typical: 0 dBm)
Receiving Sensitivity	-96 dBm
Data Rate	1 Mbps, 2 Mbps
Power Consumption	4.6 mA peak current in TX (@ 0 dBm) 4.6 mA peak current in RX
GPIO	16
Crystal	32 MHz, 32.768 kHz
RAM	24 KB
Flash	192 KB
Package	SMT Packaging (1.27-mm half-hole pitch stamp stick)
Frequency Error	±20 kHz
Dimension	15.2 mm x 11.2 mm x 1.7 mm
Type of Antenna	PCB Antenna / half-hole antenna interface
Operating Temperature	-40 °C ~ +85 °C
Storage Temperature	-40 °C ~ +125 °C

2.2 Module Pin Diagram

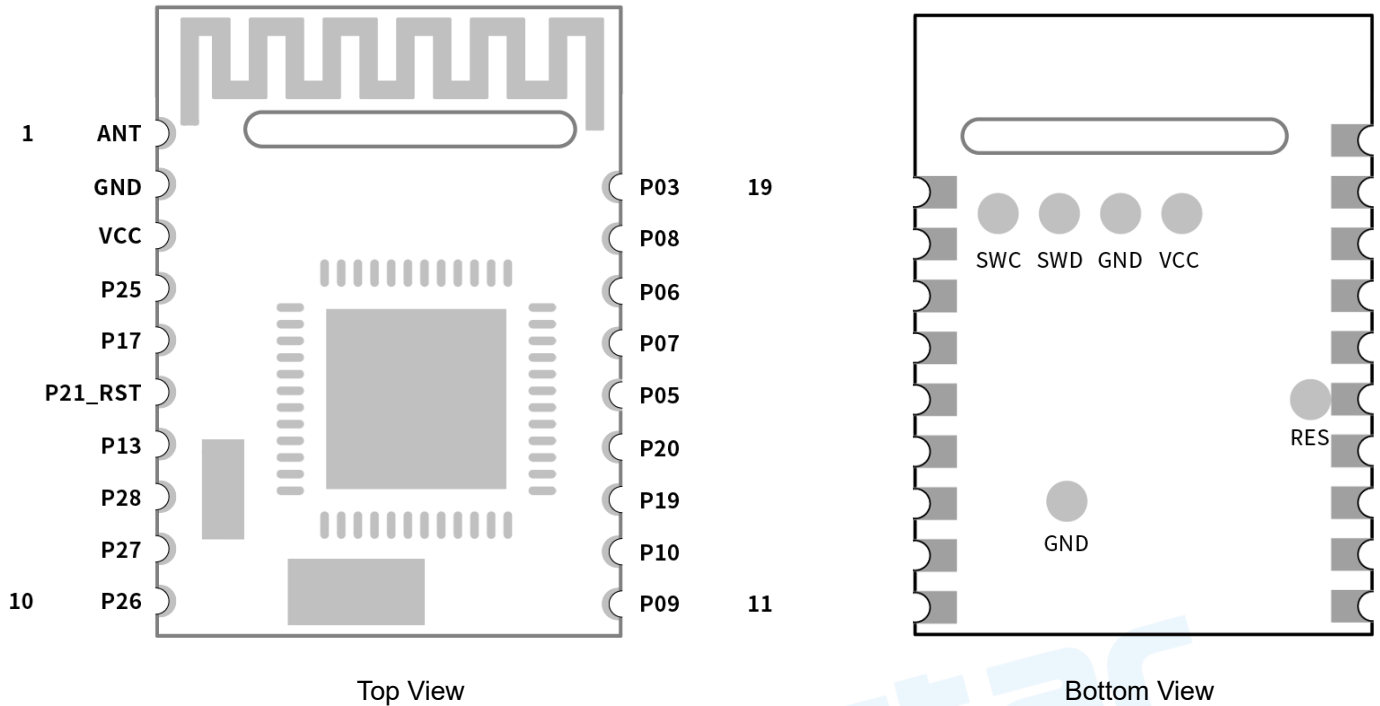

Figure 3. Pin Diagram of RF-BM-ND08C

2.3 Pin Functions

Table 2. Pin Functions of RF-BM-ND08C

Pin	Name	Chip Pin	Pin Type	Description
1	ANT	-	-	Antenna interface. Need to remove two components and see the details Antenna chapter.
2	GND	GND	GND	Ground
3	VCC	VCC	VCC	Power supply 1.7 V ~ 3.6 V, Recommend 3.3 V
4	P25	P0.25	Digital I/O	General purpose I/O
5	P17	P0.17	Digital I/O	General purpose I/O
6	P21/RST	P0.21 nRESET	Digital I/O	General purpose I/O Reset, active low. Internal pullup.
7	P13	P0.13	Digital I/O	General purpose I/O
8	P28	P0.28/AIN4	Digital I/O Analog input	General purpose I/O SAADC/COMP input
9	P27	P0.27	Digital I/O	General purpose I/O

10	P26	P0.26	Digital I/O	General purpose I/O
11	P09	P0.09	Digital I/O	General purpose I/O
12	P10	P0.10	Digital I/O	General purpose I/O
13	P19	P0.19	Digital I/O	General purpose I/O
14	P20	P0.20	Digital I/O	General purpose I/O
15	P05	P0.05/AIN3	Digital I/O Analog input	General purpose I/O SAADC/COMP input
16	P07	P0.07	Digital I/O	General purpose I/O
17	P06	P0.06	Digital I/O	General purpose I/O
18	P08	P0.08	Digital I/O	General purpose I/O
19	P03	P0.03/AIN1	Digital I/O Analog input	General purpose I/O SAADC/COMP input

Note:

SWD debugging ports are on the bottom side of the module, which is not pulled out in the stamp half hole way, please refer to the module pin diagram for details.

3 Specifications

3.1 Recommended Operating Conditions

The functional operation does not guarantee performance beyond the limits of the conditional parameter values in the table below. Long-term work beyond this limit will affect the reliability of the module more or less.

Table 3. Recommended Operating Conditions of RF-BM-ND08C

Items	Condition	Min.	Typ.	Max.	Unit
Operating Supply Voltage	Battery Mode	1.7	3.3	3.6	V
Operating Temperature	/	-40	+25	+85	°C
Environmental Hot Pendulum	/	-20		+20	°C/min

Notes:

3.2 Handling Ratings

Table 4. Handling Ratings of RF-BM-ND08C

Items	Condition	Min.	Typ.	Max.	Unit
Storage Temperature	Tstg	-40	+25	+125	°C
Human Body Model	HBM		±4000		V
Moisture Sensitivity Level			3		
Charged Device Model			±1000		V

3.3 Power Consumption

Table 5. Power Consumption

Event	Average Current	Testing Conditions / Remark
Sleeping	1.23 μ A	EN disconnected
Broadcast	70.33 μ A	Broadcast cycle: 200 ms
Broadcast	28.38 μ A	Broadcast cycle: 500 ms
Broadcast	14.02 μ A	Broadcast cycle: 1000 ms
Broadcast	7.64 μ A	Broadcast cycle: 2000 ms
Broadcast	3.49 μ A	Broadcast cycle: 5000 ms
Connection	64.72 μ A	Connection cycle: 50 ms
Connection	33.80 μ A	Connection cycle: 100 ms

4 Application, Implementation, and Layout

4.1 Module Photos

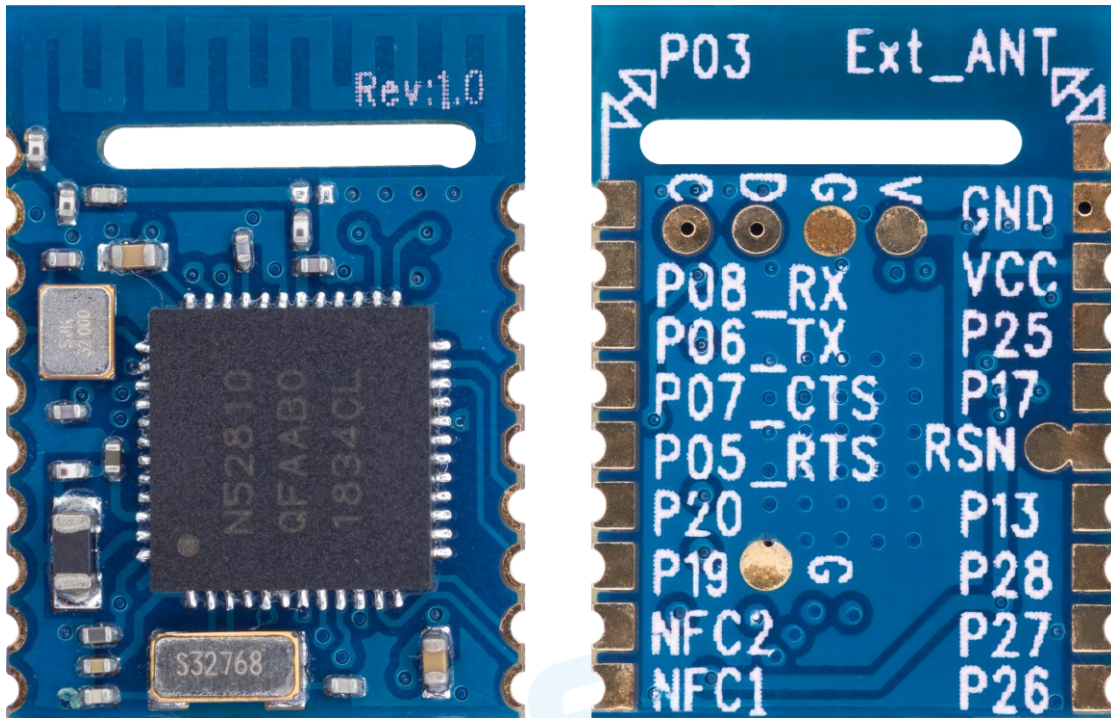

Figure 4. Photos of RF-BM-ND08C

4.2 Recommended PCB Footprint

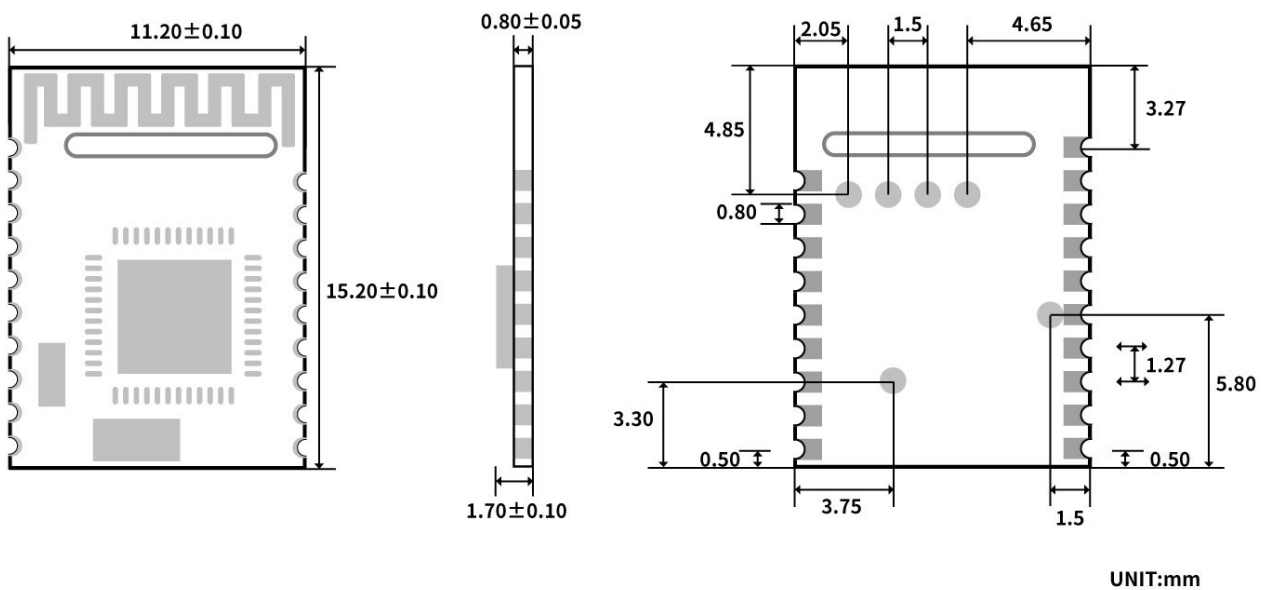

Figure 5. Recommended PCB Footprint of RF-BM-ND08C (mm)

4.3 Schematic Diagram

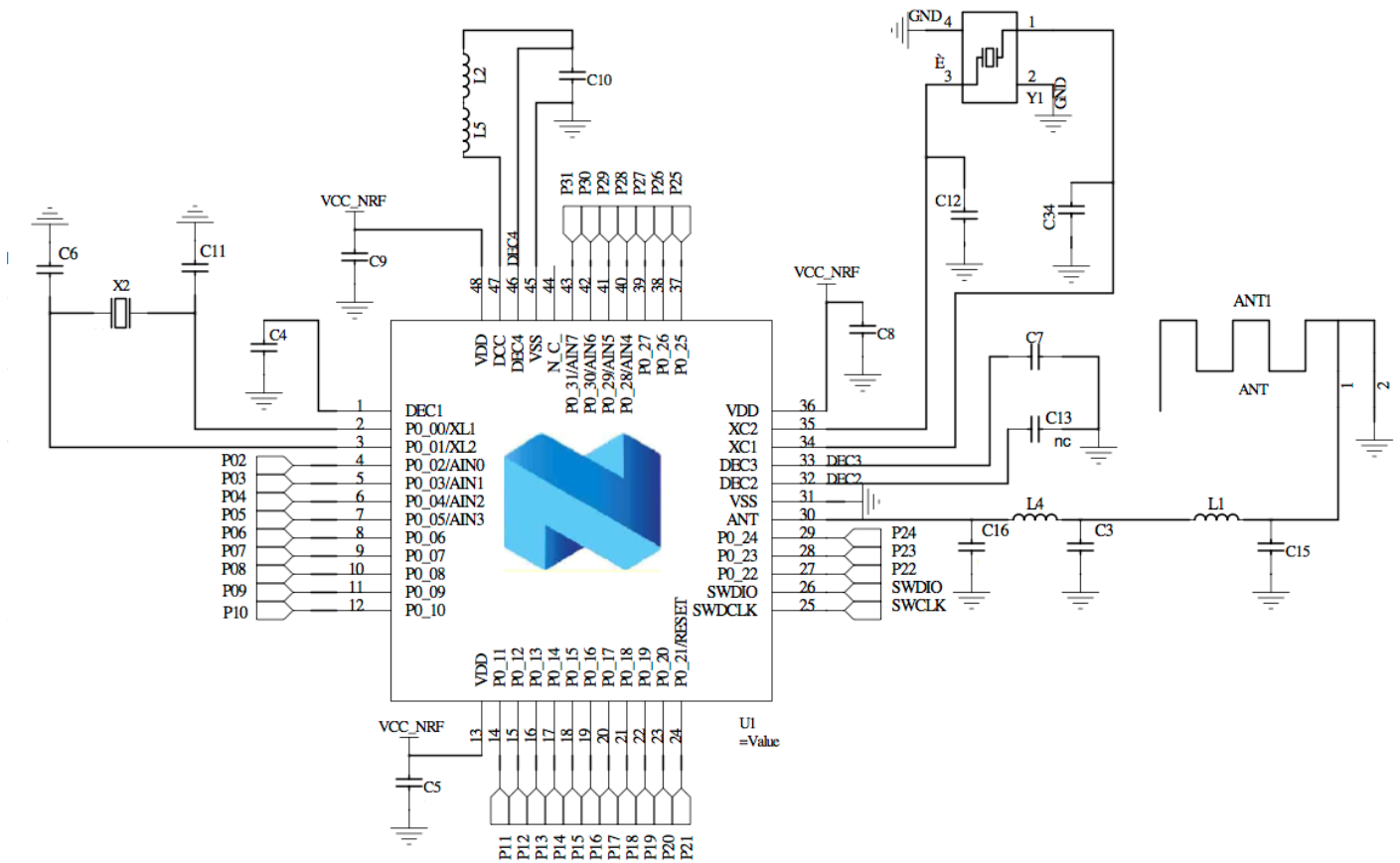

Figure 6. Schematic Diagram of RF-BM-ND08C

4.4 Reference Design

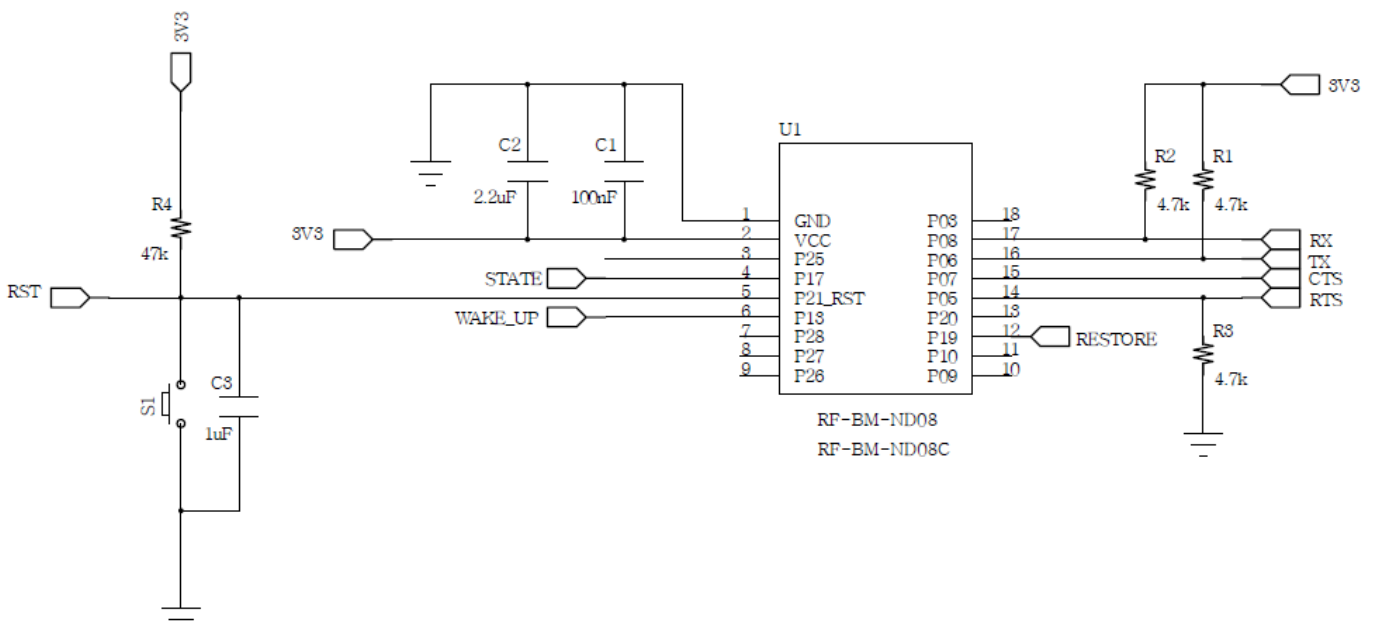

Figure 7. Reference Design of RF-BM-ND08C

4.5 Antenna

4.5.1 Antenna Design Recommendation

1. The antenna installation structure has a great influence on the module performance. It is necessary to ensure the antenna is exposed and preferably vertically upward. When the module is installed inside of the case, a high-quality antenna extension wire can be used to extend the antenna to the outside of the case.
2. The antenna must not be installed inside the metal case, which will cause the transmission distance to be greatly weakened.
3. The recommendation of antenna layout.

The inverted-F antenna position on PCB is free-space electromagnetic radiation. The location and layout of the antenna is a key factor to increase the data rate and transmission range.

Therefore, the layout of the module antenna location and routing is recommended as follows:

- (1) Place the antenna on the edge (corner) of the PCB.
- (2) Make sure that there is no signal line or copper foil in each layer below the antenna.
- (3) It is best to hollow out the antenna position in the following figure to ensure that the S11 of the module is minimally affected.

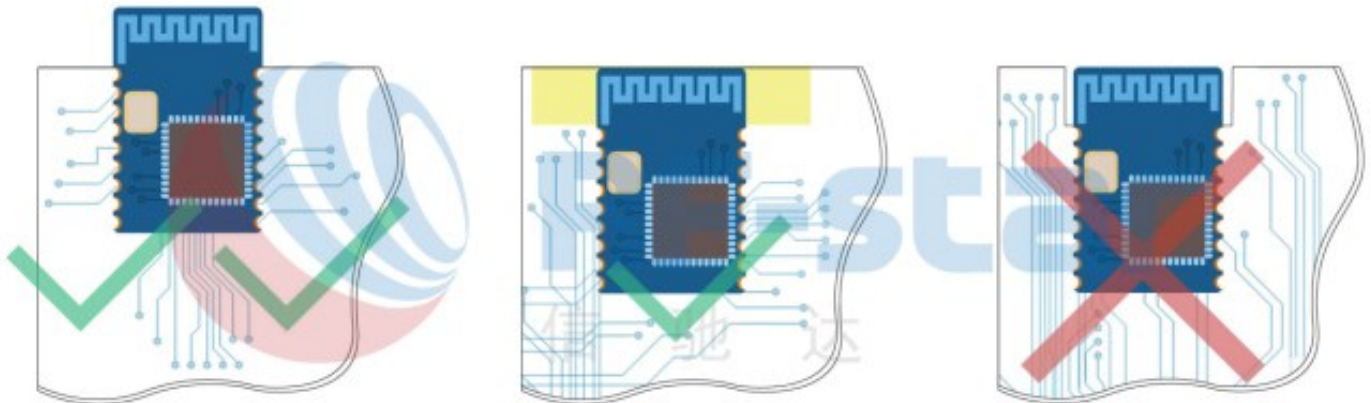

Figure 8. Recommendation of Antenna Layout

Note: The hollow-out position is based on the antenna used.

4.5.2 Antenna Output Mode Modification

The module has two antenna output modes, which are onboard PCB antenna and stamp half-hole output (ANT pin, see pin function table for details).

The default delivery is the onboard PCB antenna. If the ANT pin is needed to be used, remove the two components in the following red circless shown in the figure below.



Figure 9. Antenna Output Mode Change

4.5.3 External Antenna Design Recommendation of the Half-Hole ANT Pin

1. A Π -type matching circuit is reserved for the antenna, and $50\ \Omega$ impedance control is performed on the RF traces. The traces are as short as possible, and 135° or arc traces are used as much as possible. No vias are used to change layers. More GND vias are placed around the RF traces.

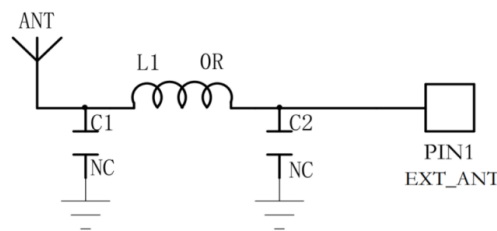

Figure 10. Reference Design of the External Antenna

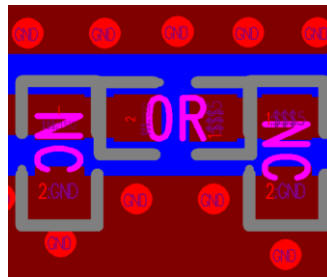

Figure 11. Reference Design of the External Antenna Traces

2. The RF trace width and copper-clad spacing can be calculated by SI9000 software, and the impedance is controlled to $50\ \Omega$ according to the actual board thickness, number of layers, plate, dielectric thickness, dielectric constant, copper thickness, line width, line spacing, and solder mask thickness.

Example: FR4 is a double-layer board with a thickness of 1.0 mm. Through calculation, the width of the trace is 0.8254 mm, and the spacing between traces and copper is 0.22 mm.

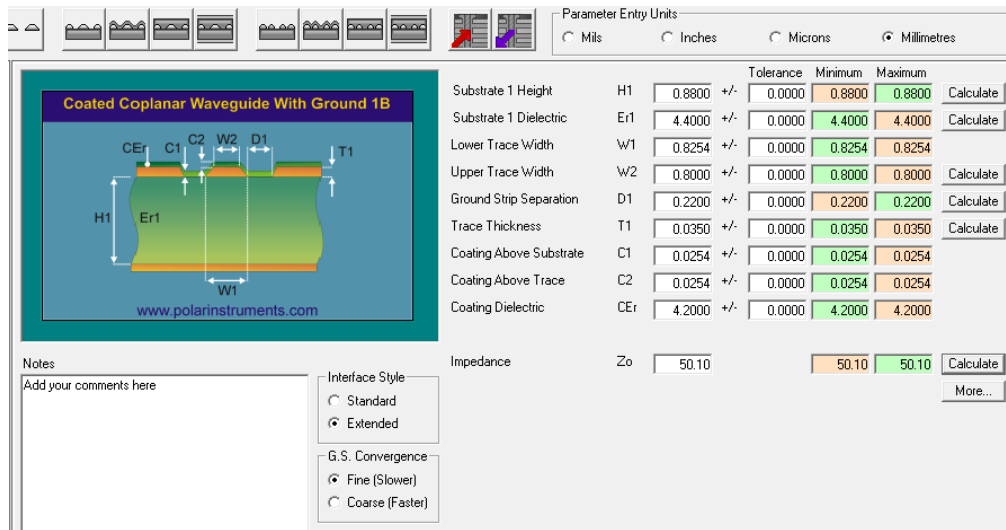

Figure 12. SI9000 Impedance Calculation Diagram

4.6 Basic Operation of Hardware Design

1. It is recommended to offer the module with a DC stabilized power supply, a tiny power supply ripple coefficient, and reliable ground. Please pay attention to the correct connection between the positive and negative poles of the power supply. Otherwise, the reverse connection may cause permanent damage to the module;
2. Please ensure the supply voltage is between the recommended values. The module will be permanently damaged if the voltage exceeds the maximum value. Please ensure a stable power supply and no frequently fluctuated voltage.
3. When designing the power supply circuit for the module, it is recommended to reserve more than 30% of the margin, which is beneficial to the long-term stable operation of the whole machine. The module should be far away from the power electromagnetic, transformer, high-frequency wiring, and other parts with large electromagnetic interference.
4. The bottom of the module should avoid high-frequency digital routing, high-frequency analog routing, and power routing. If it has to route the wire on the bottom of the module, for example, it is assumed that the module is soldered to the Top Layer, the copper must be spread on the connection part of the top layer and the module, and be close to the digital part of the module and routed in the Bottom Layer (all copper is well-grounded).
5. Assuming that the module is soldered or placed in the Top Layer, it is also wrong to randomly route the Bottom Layer or other layers, which will affect the spurs and receiving sensitivity of the module to some degrees;
6. Assuming that there are devices with large electromagnetic interference around the module, which will greatly affect the module performance. It is recommended to stay away from the module according to the strength of the interference. If circumstances permit, appropriate isolation and shielding can be done.
7. Assuming that there are routings of large electromagnetic interference around the module (high-frequency digital, high-frequency analog, power routings), which will also greatly affect the module performance. It is recommended to stay away from the module according to the strength of the interference. If circumstances permit, appropriate

isolation and shielding can be done.

8. It is recommended to stay away from the devices whose TTL protocol is the same 2.4 GHz physical layer, for example, USB 3.0.

4.7 Trouble Shooting

4.7.1 Unsatisfactory Transmission Distance

1. When there is a linear communication obstacle, the communication distance will be correspondingly weakened. Temperature, humidity, and co-channel interference will lead to an increase in communication packet loss rate. The performances of ground absorption and reflection of radio waves will be poor when the module is tested close to the ground.
2. Seawater has a strong ability to absorb radio waves, so the test results by the seaside are poor.
3. The signal attenuation will be very obvious if there is a metal near the antenna or the module is placed inside the metal shell.
4. The incorrect power register set or the high data rate in an open-air may shorten the communication distance. The higher the data rate, the closer the distance.
5. The low voltage of the power supply is lower than the recommended value at ambient temperature, and the lower the voltage, the smaller the power is.
6. The unmatchable antennas and modules or the poor quality of the antenna will affect the communication distance.

4.7.2 Vulnerable Module

1. Please ensure the supply voltage is between the recommended values. The module will be permanently damaged if the voltage exceeds the maximum value. Please ensure a stable power supply and no frequently fluctuated voltage.
2. Please ensure the anti-static installation and the electrostatic sensitivity of high-frequency devices.
3. Due to some humidity-sensitive components, please ensure suitable humidity during installation and application. If there is no special demand, it is not recommended to use at too high or too low temperature.

4.7.3 High Bit Error Rate

1. There are co-channel signal interferences nearby. It is recommended to be away from the interference sources or modify the frequency and channel to avoid interferences.
2. The unsatisfactory power supply may also cause garbled. It is necessary to ensure the power supply's reliability.
3. If the extension wire or feeder wire is of poor quality or too long, the bit error rate will be high.

4.8 Electrostatics Discharge Warnings

The module will be damaged for the discharge of static. RF-star suggests that all modules should follow the 3 precautions

below:

1. According to the anti-static measures, bare hands are not allowed to touch modules.
2. Modules must be placed in anti-static areas.
3. Take the anti-static circuitry (when inputting HV or VHF) into consideration in product design.
Static may result in the degradation in performance of the module, even causing the failure.

4.9 Soldering and Reflow Condition

1. Heating method: Conventional Convection or IR/convection.
2. Solder paste composition: Sn96.5 / Ag3.0 / Cu0.5
3. Allowable reflow soldering times: 2 times based on the following reflow soldering profile.
4. Temperature profile: Reflow soldering shall be done according to the following temperature profile.
5. Peak temperature: 245 °C.

Table 6. Temperature Table of Soldering and Reflow

Profile Feature	Sn-Pb Assembly	Pb-Free Assembly
Solder Paste	Sn63 / Pb37	Sn96.5 / Ag3.0 / Cu0.5
Min. Preheating Temperature (T_{min})	100 °C	150 °C
Max. Preheating Temperature (T_{max})	150 °C	200 °C
Preheating Time (T_{min} to T_{max}) (t_1)	60 s ~ 120 s	60 s ~ 120 s
Average Ascend Rate (T_{max} to T_p)	Max. 3 °C/s	Max. 3 °C/s
Liquid Temperature (T_L)	183 °C	217 °C
Time above Liquidus (t_L)	60 s ~ 90 s	30 s ~ 90 s
Peak Temperature (T_p)	220 °C ~ 235 °C	230 °C ~ 250 °C
Average Descend Rate (T_p to T_{max})	Max. 6 °C/s	Max. 6 °C/s
Time from 25 °C to Peak Temperature (t_2)	Max. 6 minutes	Max. 8 minutes
Time of Soldering Zone (t_p)	20±10 s	20±10 s

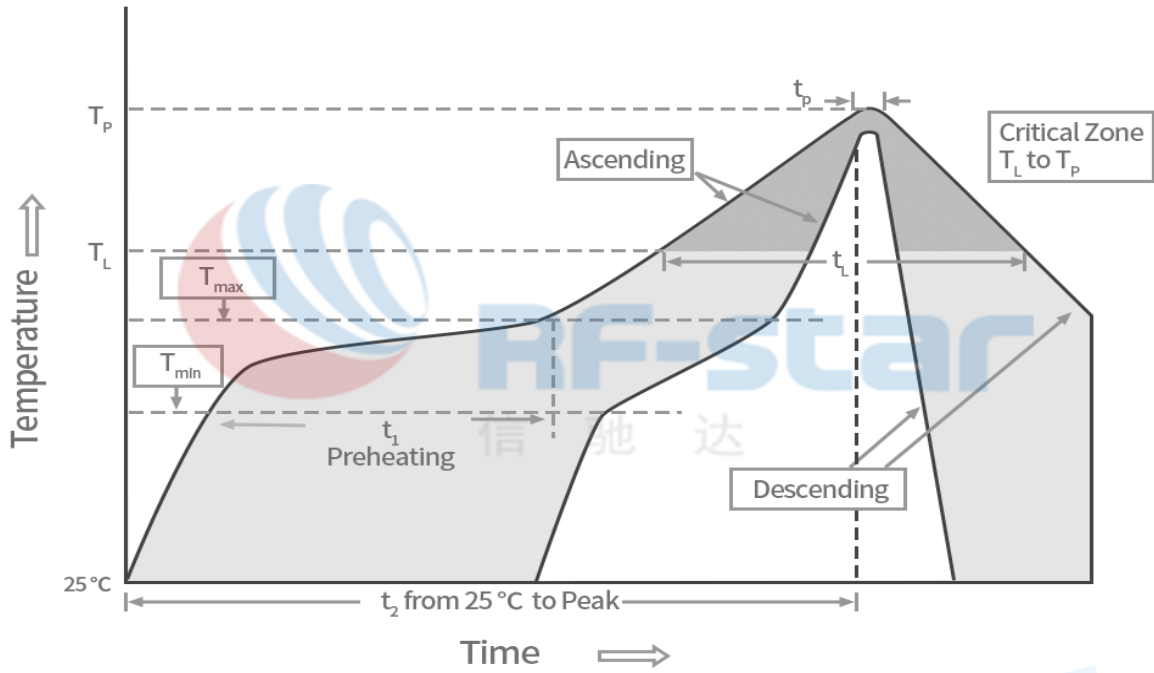

Figure 13. Recommended Reflow for Lead-Free Solder

5 Optional Package Specification

The default package method is **by tray**. If you need the modules to be shipped by tape & reel, pls contact us in advance.

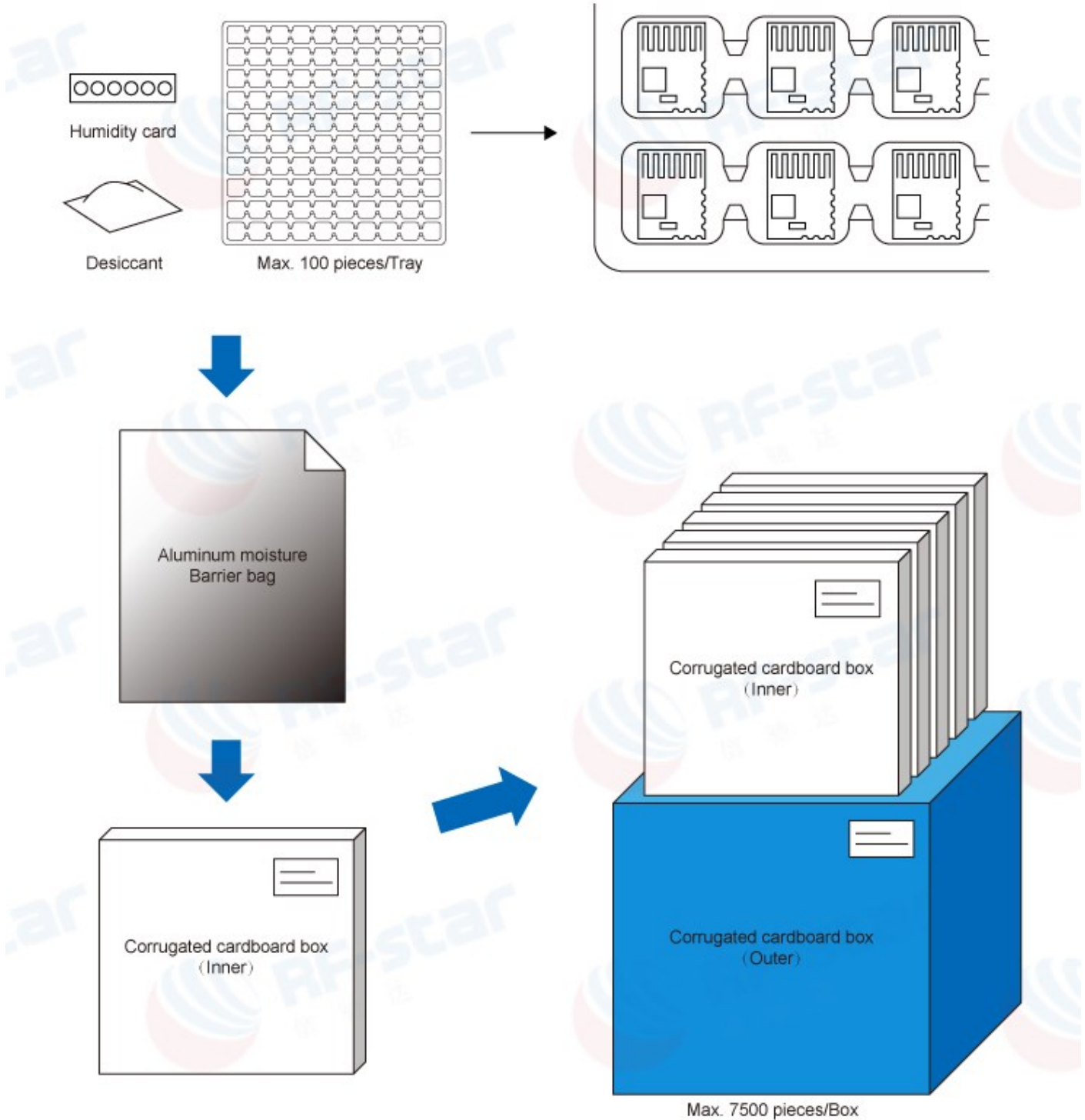

Figure 14. Default Package by Tray

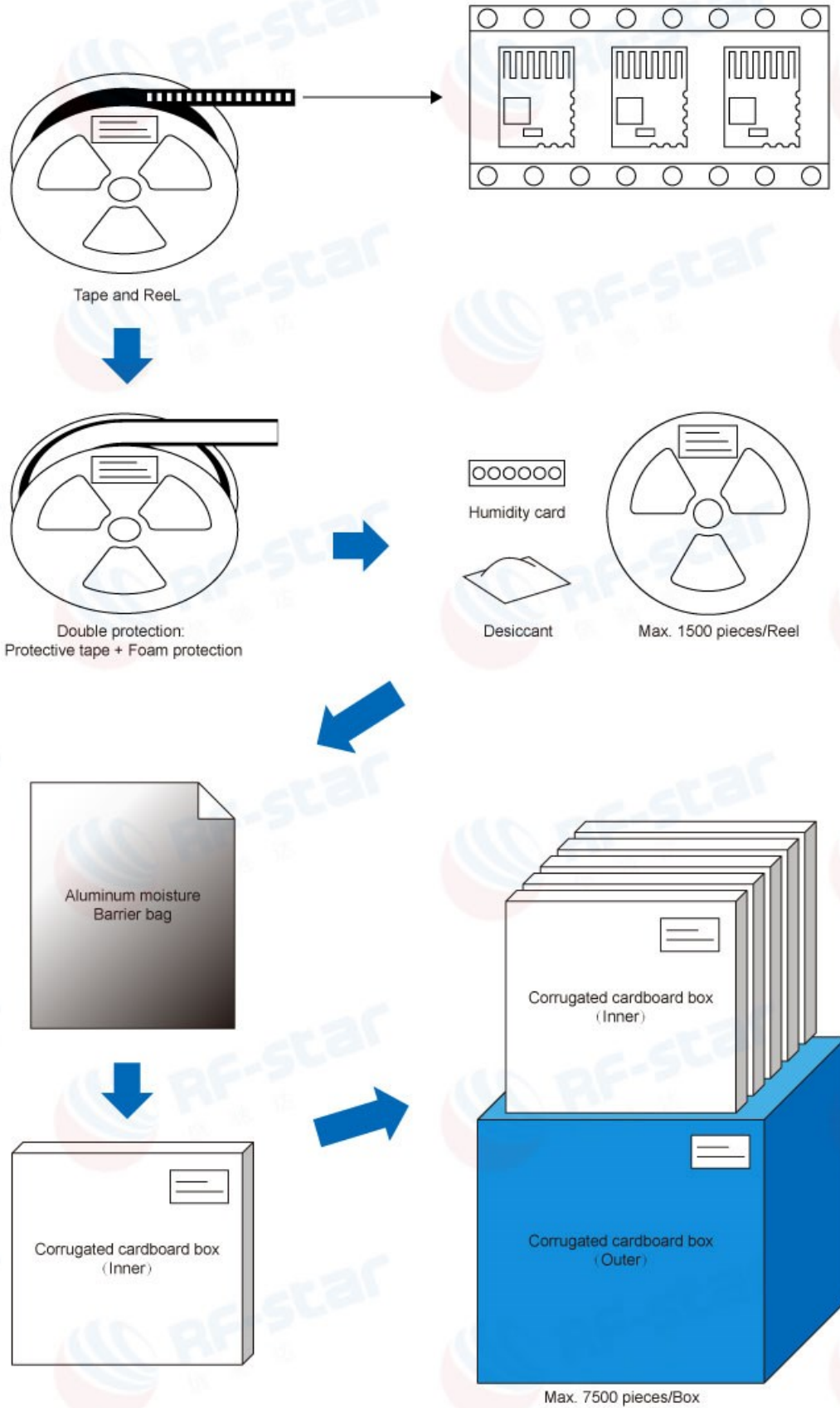

Figure 15. Package by Tape & Reel

6 Certification

6.1 SRRC

CMIIT ID: 2021DP16258(M)



Figure 16. SRRC Certificate of RF-BM-ND08C

7 Revision History

Date	Version No.	Description
2020.04.24	V1.0	The initial version is released.
2020.05.15	V1.1	Add antenna output mode change specification. Add module photo.
2020.08.12	V1.2	Add the SWD debugging ports specification.
2023.05.26	V1.2	Update MSL level. Add the certificate. Update the Shenzhen office address.
2023.07.24	V1.3	Update the antenna output mode.

Note:

1. The document will be optimized and updated from time to time. Before using this document, please make sure it is the latest version.
2. To obtain the latest document, please download it from the official website: www.rfstariot.com and www.szrfstar.com.

8 Contact Us

SHENZHEN RF-STAR TECHNOLOGY CO., LTD.

Shenzhen HQ:

Add.: Room A-502, Podium Building No. 12, Shenzhen Bay Science and Technology Ecological Park, Nanshan District, Shenzhen, Guangdong, China, 518063
Tel.: 86-755-8632 9829

Chengdu Branch:

Add.: N2-1604, Global Center, North No. 1700, Tianfu Avenue, Hi-Tech District, Chengdu, Sichuan, China, 610095
Tel.: 86-28-8692 5399

Email: sunny@szrfstar.com, sales@szrfstar.com

Web.: www.rfstariot.com, www.szrfstar.com

