



RF-BM-ND04C and RF-BM-ND04CI nRF52810 Bluetooth 5.0 Low Energy Module

Version 1.1

Shenzhen RF-star Technology Co., Ltd.

May 26th, 2023

All rights reserved. Those responsible for unauthorized reproduction will be prosecuted.

1 Device Overview

1.1 Module Series

There is a series of RF-BM-ND04C(I) Bluetooth 5.0 Low Energy modules. All of them are based on Nordic nRF52810 SoC. Those modules are pin-to-pin compatible with each other as well.

Table 1. Module Series of RF-BM-ND04(I)

Model	Antenna Output Mode	Chip Model	TX Power	FLASH	RAM	Protocol
ND04C	PCB onboard	nRF52810	+4 dBm	192 KB	624 KB	BLE5.0
ND04CI	IPEX connector/Half-hole RF pin					

1.2 Description

RF-BM-ND04C and RF-BM-ND04CI are RF modules based on Nordic BLE SoC nRF52810 with ARM® Cortex®-M4 32-bit processor. It integrates a 32.768 kHz and a 32 MHz crystal, an LC filter, an antenna matching and a meander line inverted-F PCB antenna or IPEX connector respectively. It supports Bluetooth 5.0 LE, including the high-speed 2 Mbps feature and ANT and 2.4 GHz proprietary protocols for simple programming. The module has numerous digital peripherals and interfaces such as PDM, PWM, UART, SPI, I²C and 12-bit ADC. It features low power consumption, small size, robust connection distance, and rigid reliability. 1.27-mm pitch stamp stick package for easy assembling and cost-effective PCB design.

1.3 Key Features

- RF features
 - Bluetooth 5.0 low energy
 - ANT
 - 2.4 GHz proprietary
- TX power: -20 to +4 dBm
- ARM® Cortex®-M4 32-bit processor, 64 MHz
- Supply voltage range 1.7 V ~ 3.6 V
- Memory
 - 192 KB flash
 - 24 KB RAM
- Support for concurrent multi-protocol
- Peripherals
 - 12-bit, 200 ksps ADC
 - 29 GPIOs
 - 4-channel PWM
 - Digital microphone interface (PDM)
 - SPI master/slave
 - I²C master/slave
 - UART (CTS/RTS)
- Programmable peripheral interconnect (PPI)
- Quadrature decoder (QDEC)
- AES HW encryption
- Dimension: 24.8 mm x 15.0 mm x 2.3 mm
- Certificates of RF-BM-ND04C: SRRRC, FCC, RoHS

1.4 Applications

- Mouse and keyboard
 - Mobile HID
 - Remote controls
 - Wearables
 - Virtual reality headsets
- Health and medical
 - Industrial lighting
 - Retail
 - Commercial
 - Beacons

1.5 Functional Block Diagram

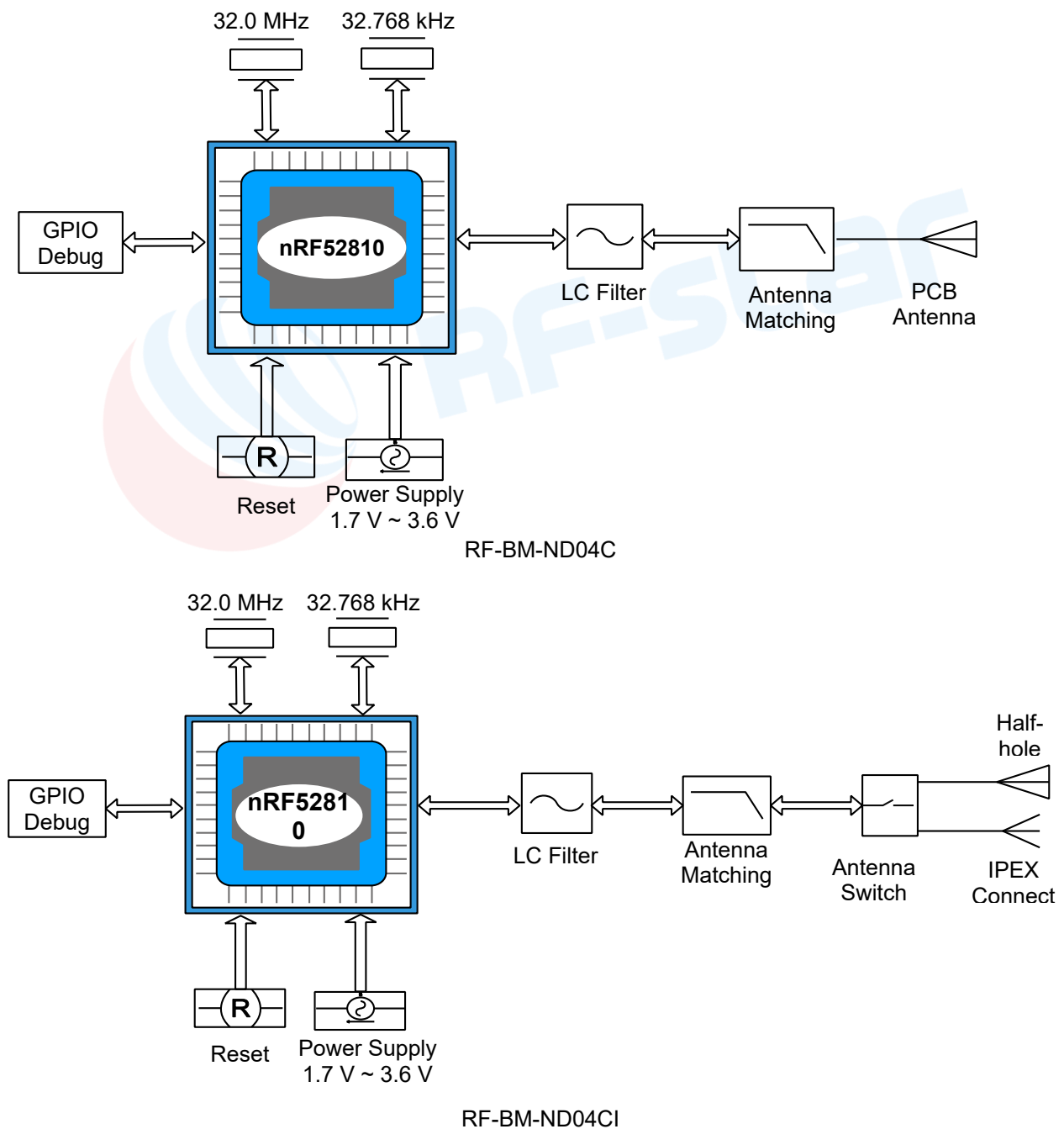

Figure 1. Functional Block Diagram of RF-BM-ND04C(I)

1.6 Part Number Conventions

The part numbers are of the form of RF-BM-ND04C(I) where the fields are defined as follows:

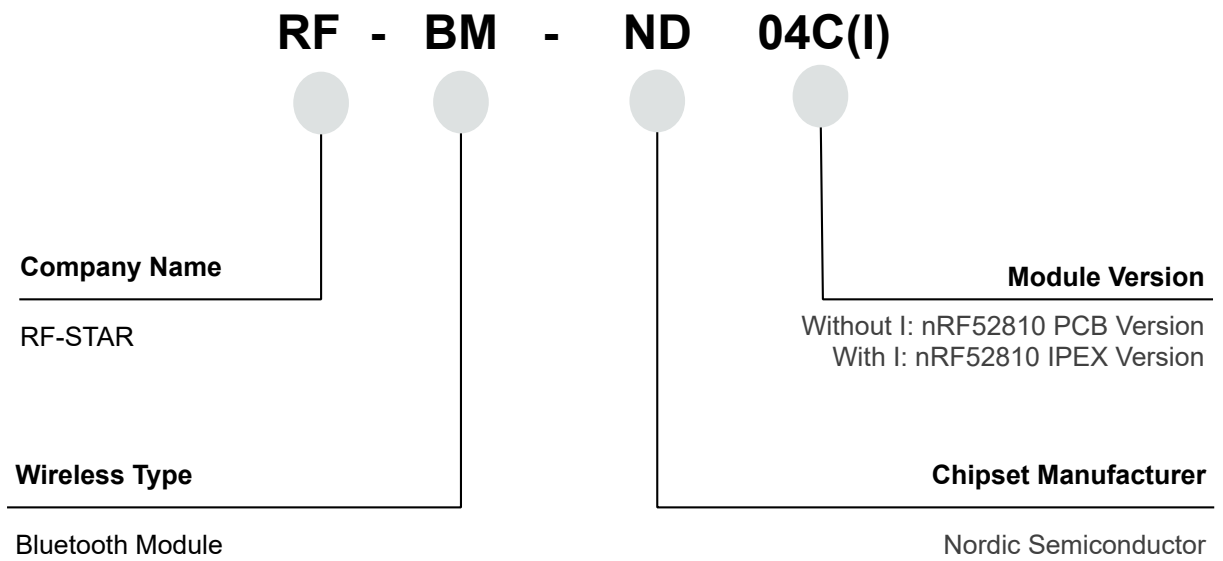

Figure 2. Part Number Conventions of RF-BM-ND04C(I)

Table of Contents

1 Device Overview	1
1.1 Module Series	1
1.2 Description.....	1
1.3 Key Features	1
1.4 Applications.....	2
1.5 Functional Block Diagram	2
1.6 Part Number Conventions	3
Table of Contents.....	4
2 Module Configuration and Functions	6
2.1 Module Parameters.....	6
2.2 Module Pin Diagram	7
2.3 Pin Functions.....	7
3 Specifications	11
3.1 Recommended Operating Conditions	11
3.2 Handling Ratings.....	11
3.3 Power Consumption	11
4 Application, Implementation, and Layout.....	12
4.1 Module Photos	12
4.2 Recommended PCB Footprint.....	12
4.3 Schematic Diagram.....	13
4.4 Reference Design	14
4.5 Antenna.....	15
4.5.1 Antenna Design Recommendation	15
4.5.2 IPEX Connector	16
4.5.3 Antenna Output Mode Modification.....	17
4.5.4 External Antenna Design Recommendation of the Half-Hole ANT Pin.....	17
4.6 Basic Operation of Hardware Design	18
4.7 Trouble Shooting	19
4.7.1 Unsatisfactory Transmission Distance.....	19
4.7.2 Vulnerable Module.....	20
4.7.3 High Bit Error Rate	20
4.8 Electrostatics Discharge Warnings	20

4.9 Soldering and Reflow Condition.....	20
5 Optional Package Specification	22
6 Certification	24
6.1 SRRC	24
6.2 FCC	24
6.3 RoHS	25
7 Revision History	26
8 Contact Us.....	27



2 Module Configuration and Functions

2.1 Module Parameters

Table 2. Parameters of RF-BM-ND04C(I)

Chipset	nRF52810
Supply Power Voltage	1.7 V ~ 3.6 V, recommended to 3.3 V
Frequency	2402 MHz ~ 2480 MHz
Transmit Power	-20.0 dBm ~ +4.0 dBm (typical: 0 dBm)
Receiving Sensitivity	-96 dBm
Data Rate	1 Mbps, 2 Mbps
Power Consumption	4.6 mA peak current in TX (@ 0 dBm) 4.6 mA peak current in RX
GPIO	29
Crystal	32 MHz, 32.768 kHz
RAM	24 KB
Flash	192 KB
Package	SMT Packaging (1.27-mm half-hole pitch stamp stick)
Frequency Error	±20 kHz
Dimension	24.8 mm x 15.0 mm x 2.3 mm
Type of Antenna	RF-BM-ND04C: PCB antenna RF-BM-ND04CI: IPEX connector / half-hole RF ANT pin
Operating Temperature	-40 °C ~ +85 °C
Storage Temperature	-40 °C ~ +125 °C

2.2 Module Pin Diagram

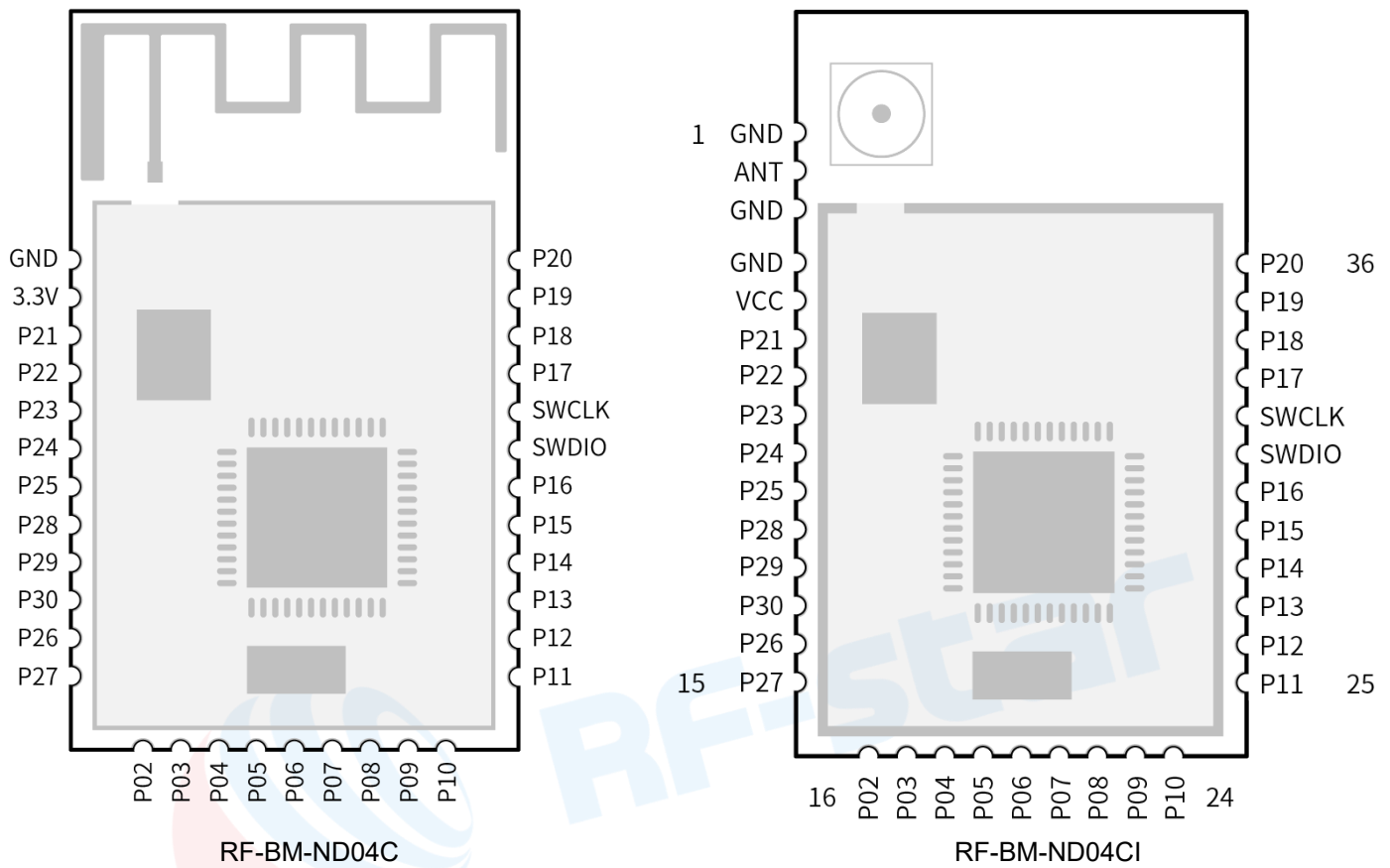

Figure 3. Pin Diagram of RF-BM-ND04C(I)

2.3 Pin Functions

Table 3. Pin Functions of RF-BM-ND04C

Pin	Name	Chip Pin	Pin Type	Description
1	GND	GND	GND	GND
2	VCC	VCC	Power	Power supply 1.7 V ~ 3.6 V, Recommend to 3.3 V
3	P21/RST	P0.21 nRESET	Digital I/O	General purpose I/O Reset, active low. Internal pullup.
4	P22	P0.22	Digital I/O	General purpose I/O
5	P23	P0.23	Digital I/O	General purpose I/O
6	P24	P0.24	Digital I/O	General purpose I/O
7	P25	P0.25	Digital I/O	General purpose I/O

8	P28	P0.28/AIN4	Digital I/O Analog input	General purpose I/O SAADC/COMP input
9	P29	P0.29/AIN5	Digital I/O Analog input	General purpose I/O SAADC/COMP input
10	P30	P0.30/AIN6	Digital I/O Analog input	General purpose I/O SAADC/COMP input
11	P26	P0.26	Digital I/O	General purpose I/O
12	P27	P0.27	Digital I/O	General purpose I/O
13	P02	P0.02/AIN0	Digital I/O Analog input	General purpose I/O SAADC/COMP input
14	P03	P0.03/AIN1	Digital I/O Analog input	General purpose I/O SAADC/COMP input
15	P04	P0.04/AIN2	Digital I/O Analog input	General purpose I/O SAADC/COMP input
16	P05	P0.05/AIN3	Digital I/O Analog input	General purpose I/O SAADC/COMP input
17	P06	P0.06	Digital I/O	General purpose I/O
18	P07	P0.07	Digital I/O	General purpose I/O
19	P08	P0.08	Digital I/O	General purpose I/O
20	P09	P0.09	Digital I/O	General purpose I/O
21	P10	P0.10	Digital I/O	General purpose I/O
22	P11	P0.11	Digital I/O	General purpose I/O
23	P12	P0.12	Digital I/O	General purpose I/O
24	P13	P0.13	Digital I/O	General purpose I/O
25	P14	P0.14	Digital I/O	General purpose I/O
26	P15	P0.15	Digital I/O	General purpose I/O
27	P16	P0.16	Digital I/O	General purpose I/O
28	SWDIO	SWDIO	Digital I/O	Serial wire debug I/O for debugging and programming

29	SWCLK	SWDCLK	Digital input	Serial wire debug clock input for debugging and programming
30	P17	P0.17	Digital I/O	General purpose I/O
31	P18	P0.18	Digital I/O	General purpose I/O
32	P19	P0.19	Digital I/O	General purpose I/O
33	P20	P0.20	Digital I/O	General purpose I/O

Table 4. Pin Functions of RF-BM-ND04C(I)

Pin	Name	Chip Pin	Pin Type	Description
1	GND	GND	GND	GND
2	ANT	ANT	ANT	Antenna output interface. Default as none use.
3	GND	GND	GND	GND
4	GND	GND	GND	GND
5	VCC	VCC	Power	Power supply 1.7 V ~ 3.6 V, Recommend 3.3 V.
6	P21/RST	P0.21 nRESET	Digital I/O	General purpose I/O Reset, active low. Internal pullup.
7	P22	P0.22	Digital I/O	General purpose I/O
8	P23	P0.23	Digital I/O	General purpose I/O
9	P24	P0.24	Digital I/O	General purpose I/O
10	P25	P0.25	Digital I/O	General purpose I/O
11	P28	P0.28/AIN4	Digital I/O Analog input	General purpose I/O SAADC/COMP input
12	P29	P0.29/AIN5	Digital I/O Analog input	General purpose I/O SAADC/COMP input
13	P30	P0.30/AIN6	Digital I/O Analog input	General purpose I/O SAADC/COMP input
14	P26	P0.26	Digital I/O	General purpose I/O
15	P27	P0.27	Digital I/O	General purpose I/O
16	P02	P0.02/AIN0	Digital I/O	General purpose I/O

			Analog input	SAADC/COMP input
17	P03	P0.03/AIN1	Digital I/O Analog input	General purpose I/O SAADC/COMP input
18	P04	P0.04/AIN2	Digital I/O Analog input	General purpose I/O SAADC/COMP input
19	P05	P0.05/AIN3	Digital I/O Analog input	General purpose I/O SAADC/COMP input
20	P06	P0.06	Digital I/O	General purpose I/O
21	P07	P0.07	Digital I/O	General purpose I/O
22	P08	P0.08	Digital I/O	General purpose I/O
23	P09	P0.09	Digital I/O	General purpose I/O
24	P10	P0.10	Digital I/O	General purpose I/O
25	P11	P0.11	Digital I/O	General purpose I/O
26	P12	P0.12	Digital I/O	General purpose I/O
27	P13	P0.13	Digital I/O	General purpose I/O
28	P14	P0.14	Digital I/O	General purpose I/O
29	P15	P0.15	Digital I/O	General purpose I/O
30	P16	P0.16	Digital I/O	General purpose I/O
31	SWDIO	SWDIO	Digital I/O	Serial wire debug I/O for debugging and programming
32	SWCLK	SWDCLK	Digital input	Serial wire debug clock input for debugging and programming
33	P17	P0.17	Digital I/O	General purpose I/O
34	P18	P0.18	Digital I/O	General purpose I/O
35	P19	P0.19	Digital I/O	General purpose I/O
36	P20	P0.20	Digital I/O	General purpose I/O

3 Specifications

3.1 Recommended Operating Conditions

Functional operation does not guarantee performance beyond the limits of the conditional parameter values in the table below. Long-term work beyond this limit will affect the reliability of the module more or less.

Table 5. Recommended Operating Conditions of RF-BM-ND04C(I)

Items	Condition	Min.	Typ.	Max.	Unit
Operating Supply Voltage	Battery Mode	1.7	3.3	3.6	V
Operating Temperature	/	-40	+25	+85	°C
Environmental Hot Pendulum	/	-20		+20	°C/min

3.2 Handling Ratings

Table 6. Handling Ratings of RF-BM-ND04C(I)

Items	Condition	Min.	Typ.	Max.	Unit
Storage Temperature	Tstg	-40	+25	+125	°C
Human Body Model	HBM		±4000		V
Moisture Sensitivity Level			3		
Charged Device Model			±1000		V

3.3 Power Consumption

Table 7. Power Consumption

Event	Average Current	Testing Conditions / Remark
Sleeping	1.23 μ A	EN disconnected
Broadcast	70.33 μ A	Broadcast cycle: 200 ms
Broadcast	28.38 μ A	Broadcast cycle: 500 ms
Broadcast	14.02 μ A	Broadcast cycle: 1000 ms
Broadcast	7.64 μ A	Broadcast cycle: 2000 ms
Broadcast	3.49 μ A	Broadcast cycle: 5000 ms
Connection	64.72 μ A	Connection cycle: 50 ms
Connection	33.80 μ A	Connection cycle: 100 ms

4 Application, Implementation, and Layout

4.1 Module Photos

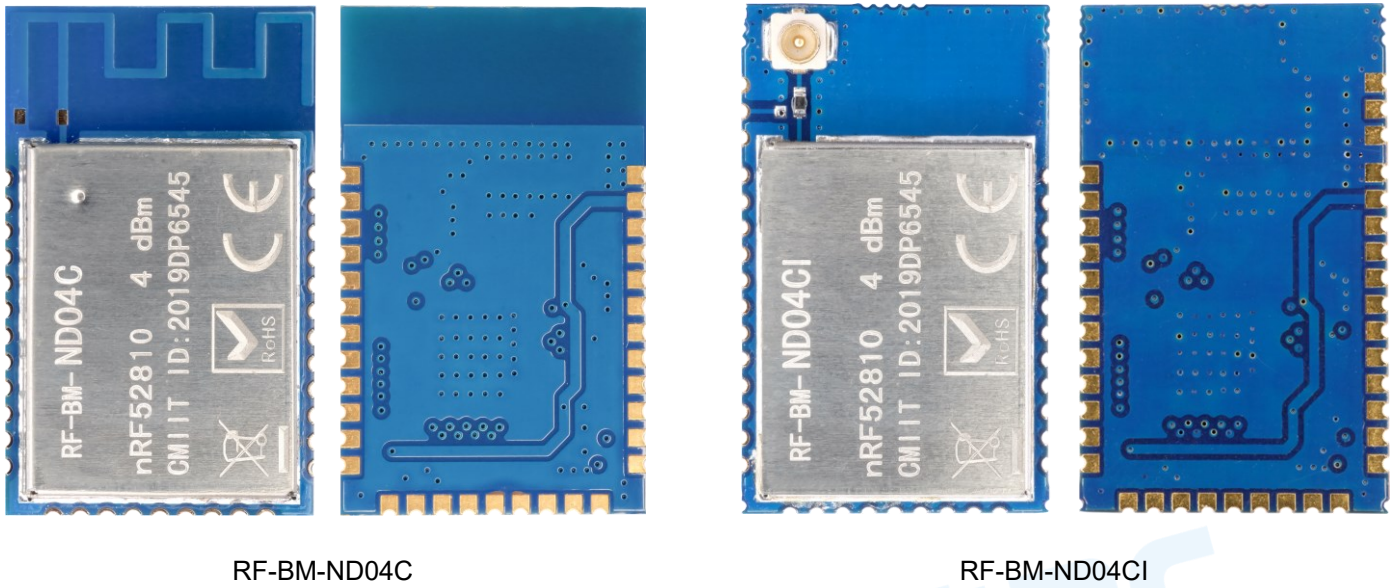

RF-BM-ND04C

RF-BM-ND04C(I)

Figure 4. Photos of RF-BM-ND04C(I)

4.2 Recommended PCB Footprint

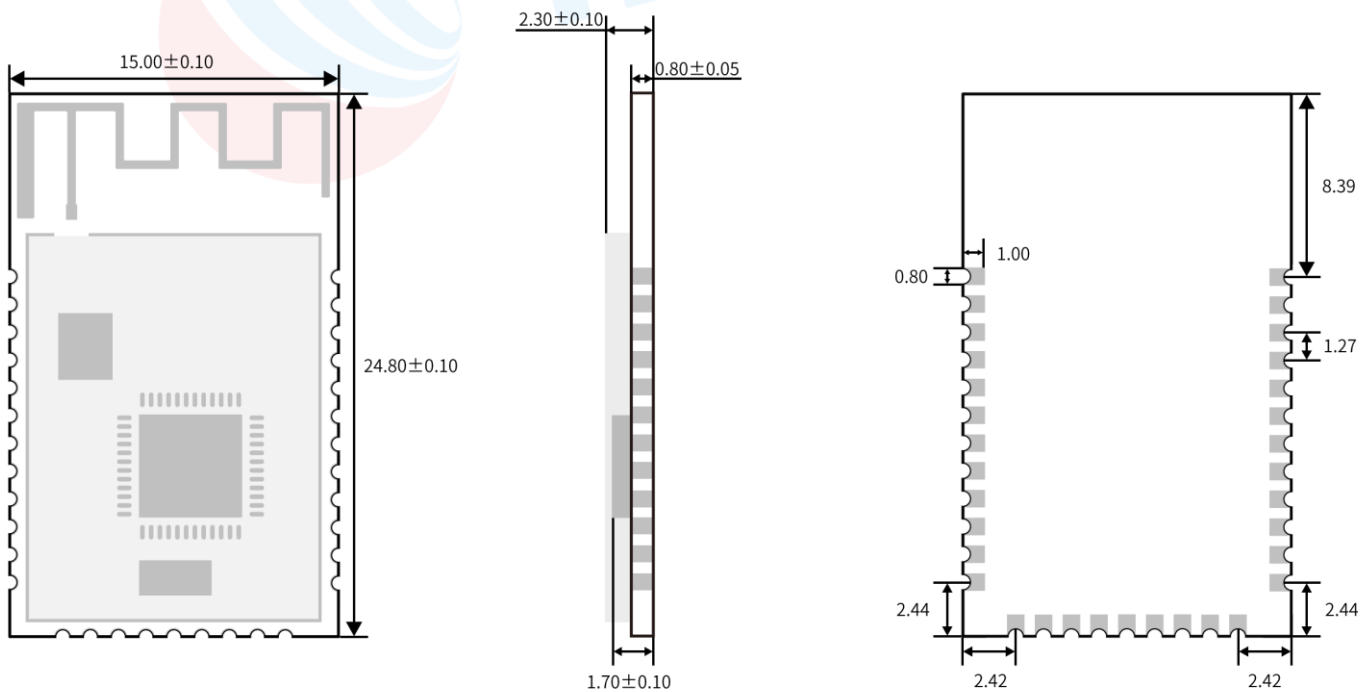

RF-BM-ND04C

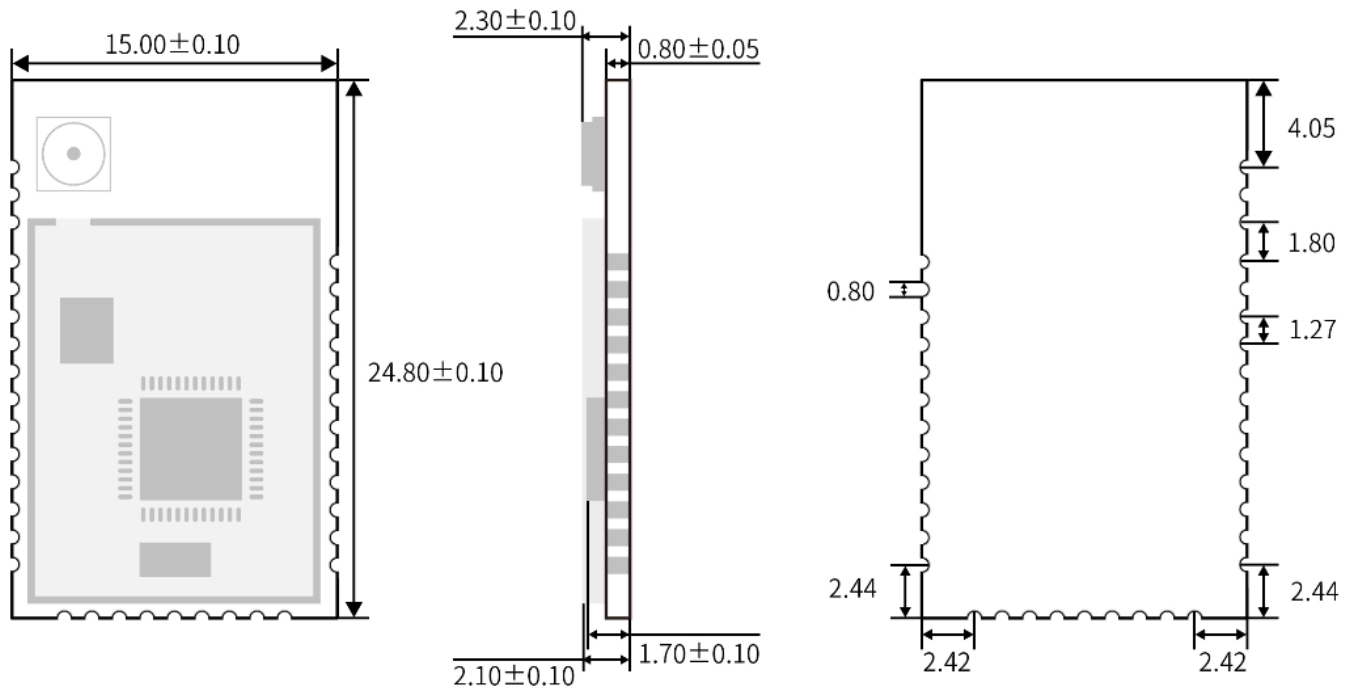

RF-BM-ND04CI

Figure 5. Recommended PCB Footprint of RF-BM-ND04C(I) (mm)

4.3 Schematic Diagram

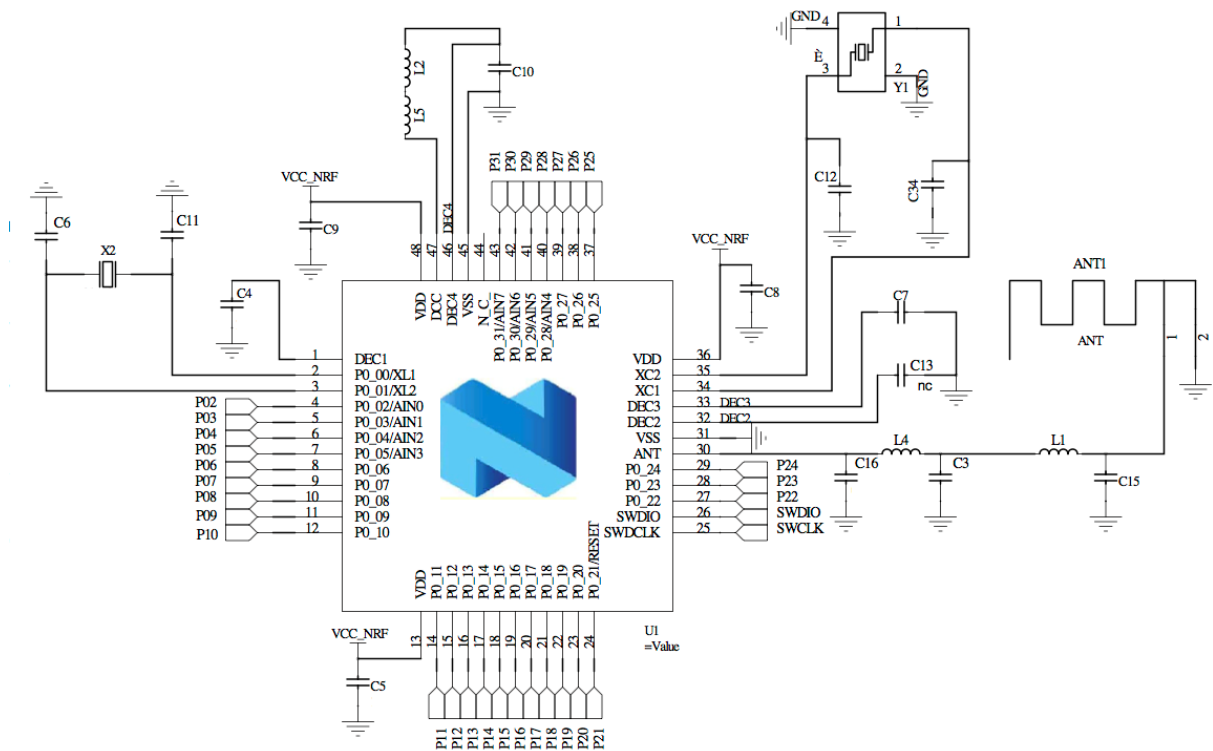

RF-BM-ND04C

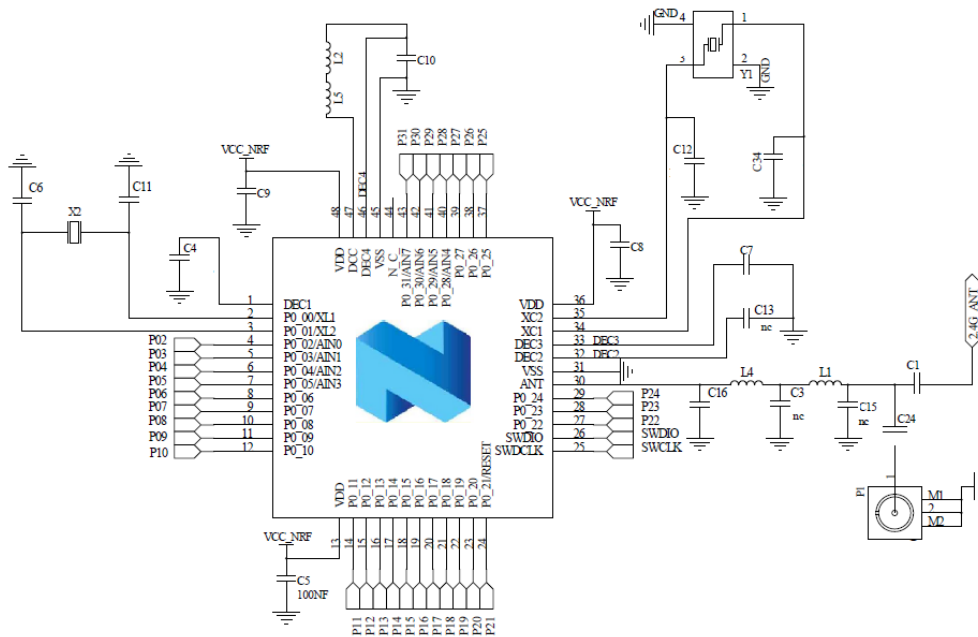

RF-BM-ND04CI

Figure 6. Schematic Diagram of RF-BM-ND04C(I)

4.4 Reference Design

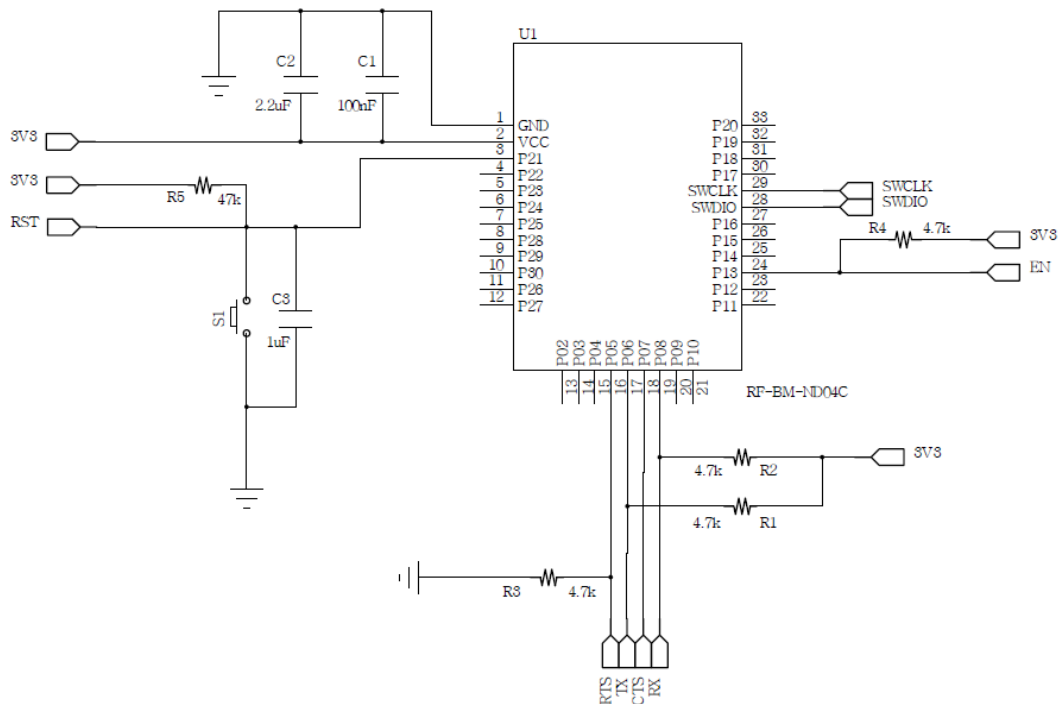

Note: EN falling edge active.

RF-BM-ND04C

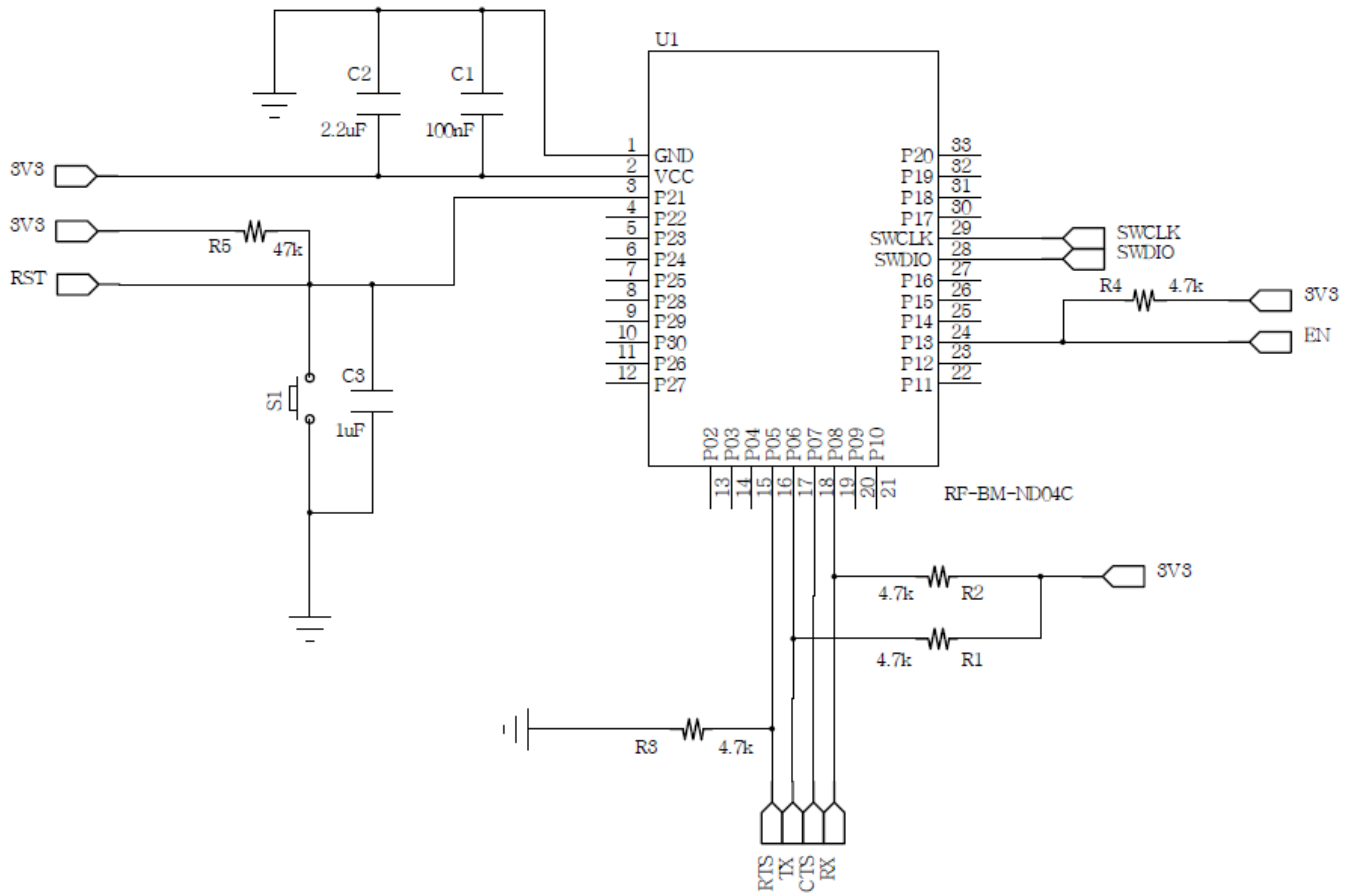

Note: EN falling edge active.

RF-BM-ND04CI

Figure 7. Reference Design of RF-BM-ND04C(I)

4.5 Antenna

4.5.1 Antenna Design Recommendation

1. The antenna installation structure has a great influence on the module performance. It is necessary to ensure the antenna is exposed and preferably vertically upward. When the module is installed inside of the case, a high-quality antenna extension wire can be used to extend the antenna to the outside of the case.
2. The antenna must not be installed inside the metal case, which will cause the transmission distance to be greatly weakened.
3. The recommendation of antenna layout.

The inverted-F antenna position on PCB is free-space electromagnetic radiation. The location and layout of the antenna is a key factor to increase the data rate and transmission range.

Therefore, the layout of the module antenna location and routing is recommended as follows:

- (1) Place the antenna on the edge (corner) of the PCB.

The specification of the IPEX wire end is as follow:

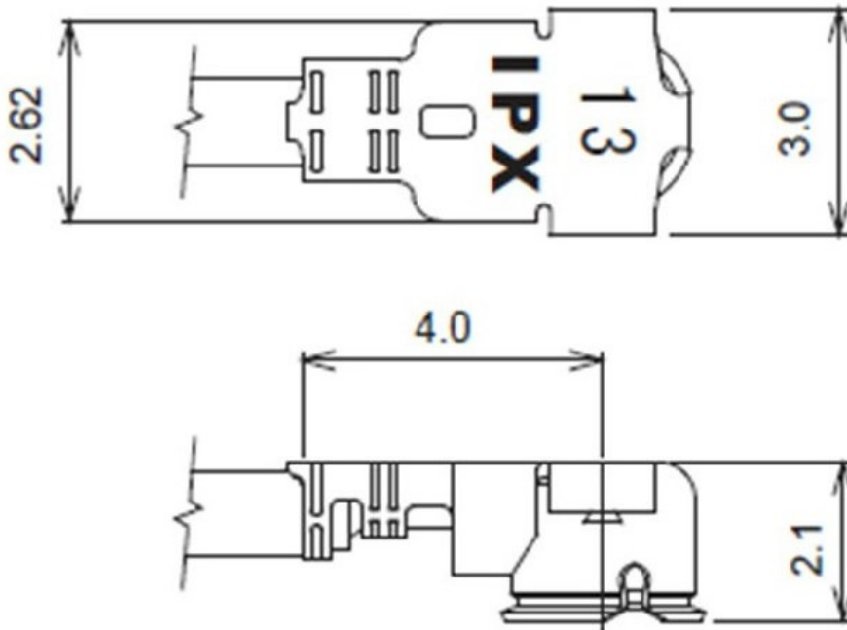

Figure 10. Specification of IPEX Wire

4.5.3 Antenna Output Mode Modification

RF-BM-ND04C(I) has two antenna output modes: IPEX connector output and stamp half-hole antenna output (ANT pin, see pin function table for details).

The default delivery is IPEX connector mode. Under IPEX connector mode, C1 is off and C2 is welded. If you would like to change to half-hole antenna output mode, please disconnect C2 and weld C1. The locations of C1 and C2 (8 pF) are shown in the figure below.

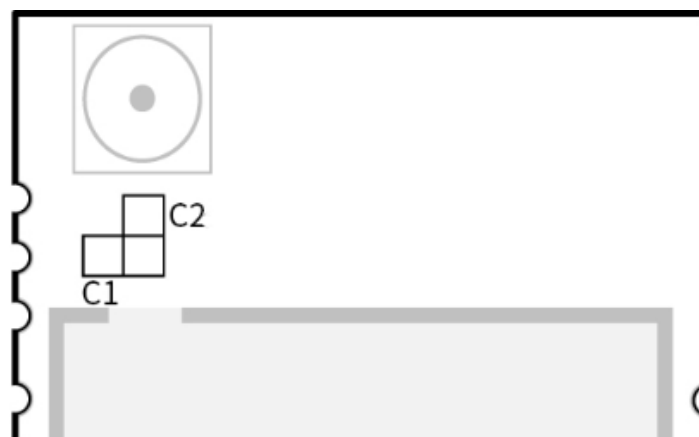

Figure 11. Antenna Output Mode Change

4.5.4 External Antenna Design Recommendation of the Half-Hole ANT Pin

1. A Π -type matching circuit is reserved for the antenna, and 50Ω impedance control is performed on the RF traces.

The traces are as short as possible, and 135° or arc traces are used as much as possible. No vias are used to change layers. More GND vias are placed around the RF traces.

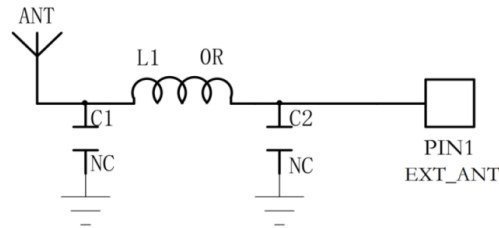

Figure 12. Reference Design of the External Antenna

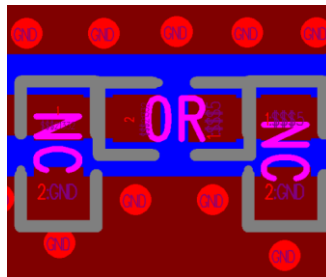

Figure 13. Reference Design of the External Antenna Traces

- The RF trace width and copper-clad spacing can be calculated by SI9000 software, and the impedance is controlled to 50 Ω according to the actual board thickness, number of layers, plate, dielectric thickness, dielectric constant, copper thickness, line width, line spacing, and solder mask thickness.

Example: FR4 is a double-layer board with a thickness of 1.0 mm. Through calculation, the width of the trace is 0.8254 mm, and the spacing between traces and copper is 0.22 mm.

Parameter	Value	Tolerance	Minimum	Maximum	Action
Substrate 1 Height	H1	0.8800 +/-	0.8800	0.8800	Calculate
Substrate 1 Dielectric	Er1	4.4000 +/-	4.4000	4.4000	Calculate
Lower Trace Width	W1	0.8254 +/-	0.8254	0.8254	Calculate
Upper Trace Width	W2	0.8000 +/-	0.8000	0.8000	Calculate
Ground Strip Separation	D1	0.2200 +/-	0.2200	0.2200	Calculate
Trace Thickness	T1	0.0350 +/-	0.0350	0.0350	Calculate
Coating Above Substrate	C1	0.0254 +/-	0.0254	0.0254	Calculate
Coating Above Trace	C2	0.0254 +/-	0.0254	0.0254	Calculate
Coating Dielectric	CEr	4.2000 +/-	4.2000	4.2000	Calculate
Impedance	Zo	50.10	50.10	50.10	Calculate

Figure 14. SI9000 Impedance Calculation Diagram

4.6 Basic Operation of Hardware Design

- It is recommended to offer the module with a DC stabilized power supply, a tiny power supply ripple coefficient, and reliable ground. Please pay attention to the correct connection between the positive and negative poles of the power

- supply. Otherwise, the reverse connection may cause permanent damage to the module;
2. Please ensure the supply voltage is between the recommended values. The module will be permanently damaged if the voltage exceeds the maximum value. Please ensure a stable power supply and no frequently fluctuated voltage.
 3. When designing the power supply circuit for the module, it is recommended to reserve more than 30% of the margin, which is beneficial to the long-term stable operation of the whole machine. The module should be far away from the power electromagnetic, transformer, high-frequency wiring, and other parts with large electromagnetic interference.
 4. The bottom of the module should avoid high-frequency digital routing, high-frequency analog routing, and power routing. If it has to route the wire on the bottom of the module, for example, it is assumed that the module is soldered to the Top Layer, the copper must be spread on the connection part of the top layer and the module, and be close to the digital part of the module and routed in the Bottom Layer (all copper is well-grounded).
 5. Assuming that the module is soldered or placed in the Top Layer, it is also wrong to randomly route the Bottom Layer or other layers, which will affect the spurs and receiving sensitivity of the module to some degrees;
 6. Assuming that there are devices with large electromagnetic interference around the module, which will greatly affect the module performance. It is recommended to stay away from the module according to the strength of the interference. If circumstances permit, appropriate isolation and shielding can be done.
 7. Assuming that there are routings of large electromagnetic interference around the module (high-frequency digital, high-frequency analog, power routings), which will also greatly affect the module performance. It is recommended to stay away from the module according to the strength of the interference. If circumstances permit, appropriate isolation and shielding can be done.
 8. It is recommended to stay away from the devices whose TTL protocol is the same 2.4 GHz physical layer, for example, USB 3.0.

4.7 Trouble Shooting

4.7.1 Unsatisfactory Transmission Distance

1. When there is a linear communication obstacle, the communication distance will be correspondingly weakened. Temperature, humidity, and co-channel interference will lead to an increase in communication packet loss rate. The performances of ground absorption and reflection of radio waves will be poor when the module is tested close to the ground.
2. Seawater has a strong ability to absorb radio waves, so the test results by the seaside are poor.
3. The signal attenuation will be very obvious if there is a metal near the antenna or the module is placed inside the metal shell.
4. The incorrect power register set or the high data rate in an open-air may shorten the communication distance. The higher the data rate, the closer the distance.
5. The low voltage of the power supply is lower than the recommended value at ambient temperature, and the lower

the voltage, the smaller the power is.

6. The unmatchable antennas and modules or the poor quality of the antenna will affect the communication distance.

4.7.2 Vulnerable Module

1. Please ensure the supply voltage is between the recommended values. The module will be permanently damaged if the voltage exceeds the maximum value. Please ensure a stable power supply and no frequently fluctuated voltage.
2. Please ensure the anti-static installation and the electrostatic sensitivity of high-frequency devices.
3. Due to some humidity-sensitive components, please ensure suitable humidity during installation and application. If there is no special demand, it is not recommended to use at too high or too low temperature.

4.7.3 High Bit Error Rate

1. There are co-channel signal interferences nearby. It is recommended to be away from the interference sources or modify the frequency and channel to avoid interferences.
2. The unsatisfactory power supply may also cause garbled. It is necessary to ensure the power supply's reliability.
3. If the extension wire or feeder wire is of poor quality or too long, the bit error rate will be high.

4.8 Electrostatics Discharge Warnings

The module will be damaged for the discharge of static. RF-star suggests that all modules should follow the 3 precautions below:

1. According to the anti-static measures, bare hands are not allowed to touch modules.
2. Modules must be placed in anti-static areas.
3. Take the anti-static circuitry (when inputting HV or VHF) into consideration in product design.
Static may result in the degradation in performance of the module, even causing the failure.

4.9 Soldering and Reflow Condition

1. Heating method: Conventional Convection or IR/convection.
2. Solder paste composition: Sn96.5 / Ag3.0 / Cu0.5
3. Allowable reflow soldering times: 2 times based on the following reflow soldering profile.
4. Temperature profile: Reflow soldering shall be done according to the following temperature profile.
5. Peak temperature: 245 °C.

Table 8. Temperature Table of Soldering and Reflow

Profile Feature	Sn-Pb Assembly	Pb-Free Assembly
Solder Paste	Sn63 / Pb37	Sn96.5 / Ag3.0 / Cu0.5
Min. Preheating Temperature (T_{min})	100 °C	150 °C
Max. Preheating Temperature (T_{max})	150 °C	200 °C
Preheating Time (T_{min} to T_{max}) (t_1)	60 s ~ 120 s	60 s ~ 120 s
Average Ascend Rate (T_{max} to T_p)	Max. 3 °C/s	Max. 3 °C/s
Liquid Temperature (T_L)	183 °C	217 °C
Time above Liquidus (t_L)	60 s ~ 90 s	30 s ~ 90 s
Peak Temperature (T_p)	220 °C ~ 235 °C	230 °C ~ 250 °C
Average Descend Rate (T_p to T_{max})	Max. 6 °C/s	Max. 6 °C/s
Time from 25 °C to Peak Temperature (t_2)	Max. 6 minutes	Max. 8 minutes
Time of Soldering Zone (t_p)	20±10 s	20±10 s

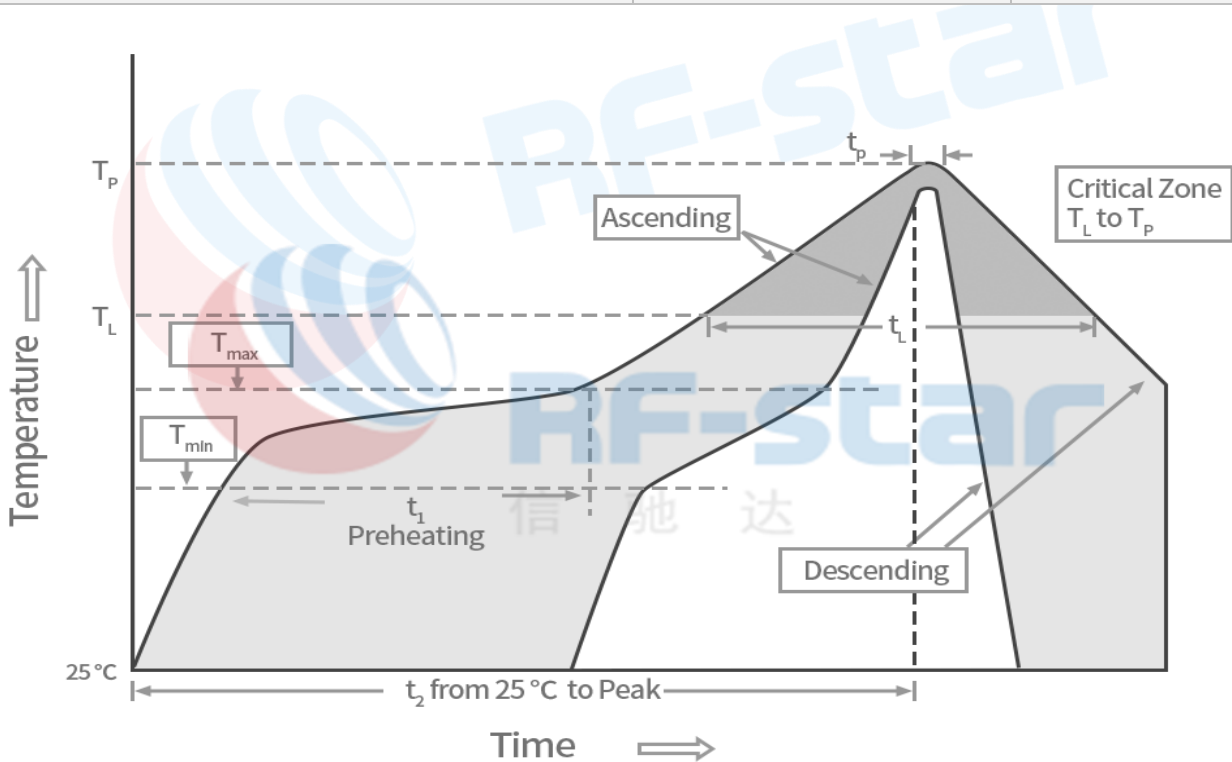

Figure 15. Recommended Reflow for Lead-Free Solder

5 Optional Package Specification

The default package method is **by tray**. If you need the modules to be shipped by tape & reel, pls contact us in advance.

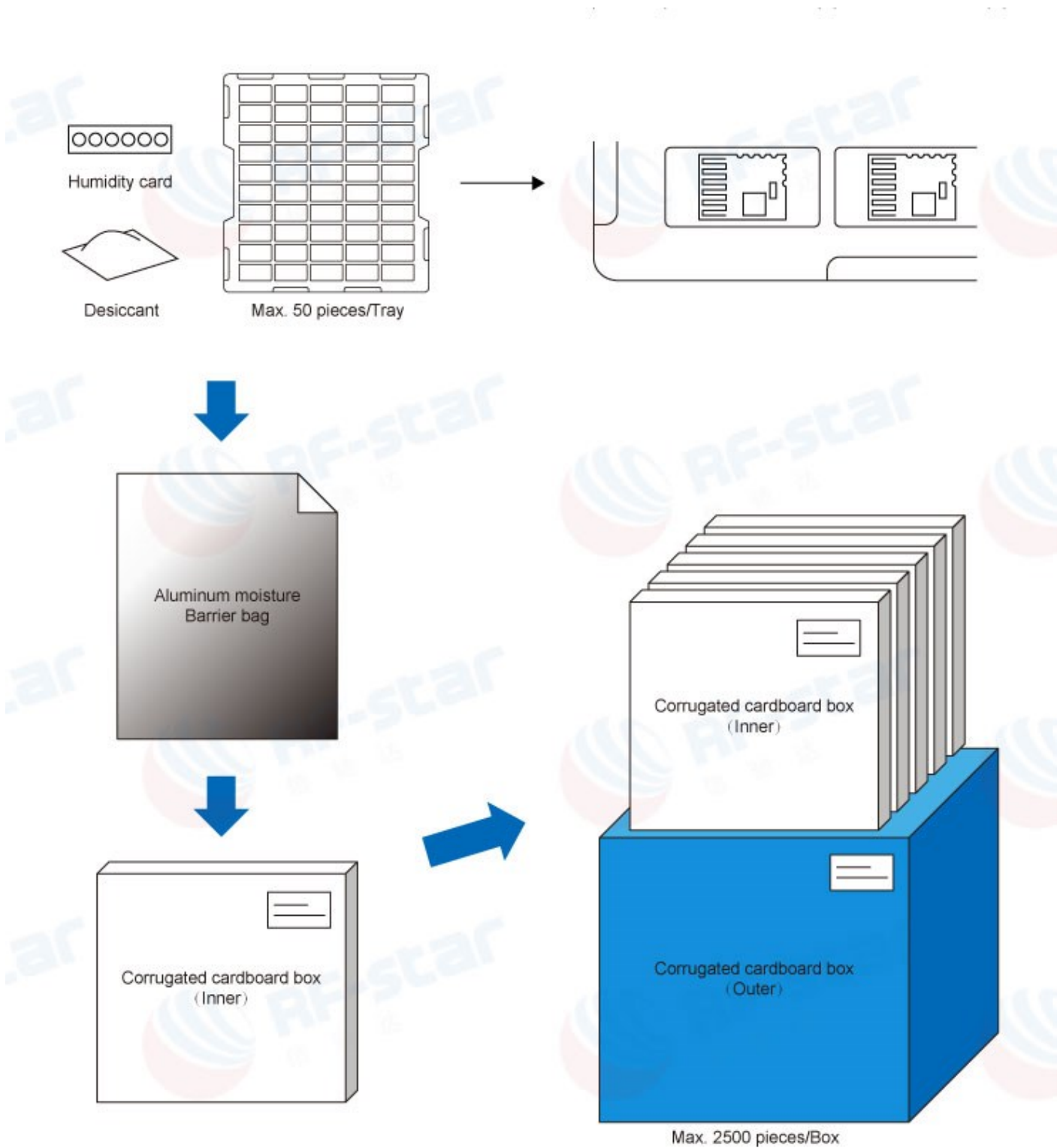

Figure 16. Default Package by Tray

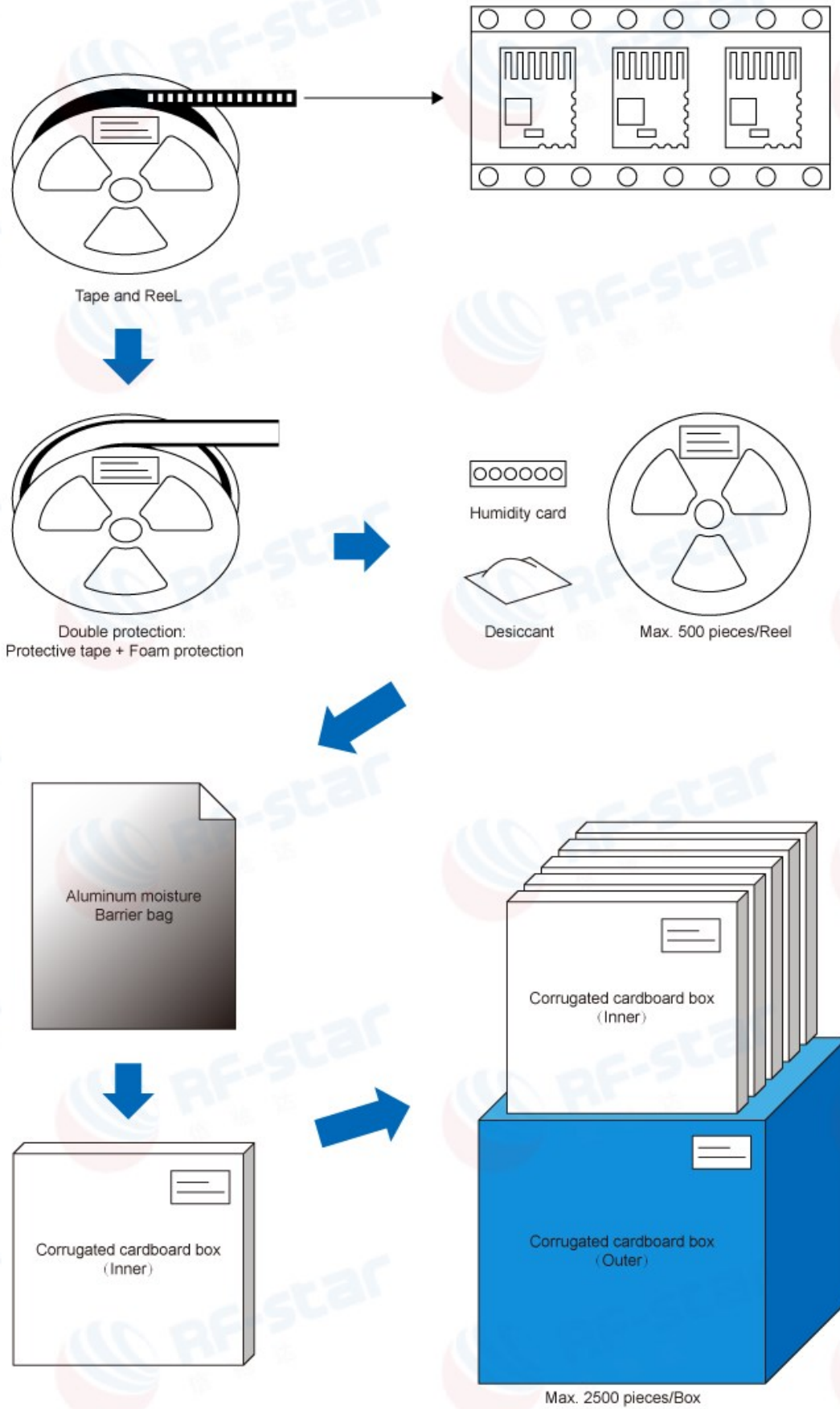

Figure 17. Package by Tape & Reel

6 Certification

6.1 SRRC

SRRC ID: 2019DP6545



Figure 18. SRRC Certificate of RF-BM-ND04C

6.2 FCC

Warnings:

This device complies with part 15 of the FCC Rules. Operation is subject to the following two conditions: (1) This device may not cause harmful interference, and (2) this device must accept any interference received, including interference that may cause undesired operation.

FCC ID: 2ABN2-ND04C

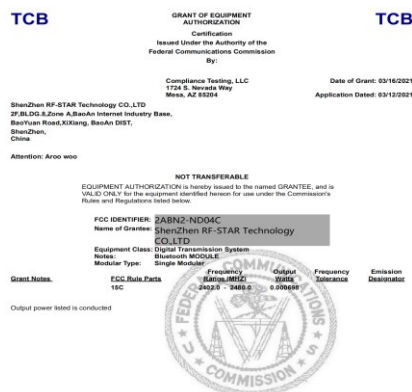

Figure 19. FCC Certificate of RF-BM-ND04C

6.3 RoHS

RoHS Report No.: C210302063001



Figure 20. RoHS Certificate of RF-BM-ND04C

7 Revision History

Date	Version No.	Description
2018.10.22	V1.0	The initial version is released.
2019.01.10	V1.1	Update parameters.
2020.01.10	V1.1	Add Nordic BLE module list.
2020.03.31	V1.1	Modify reset pin
2020.09.22	V1.1	Add reference design.
2023.05.26	V1.1	Update MSL level. Add the certificates. Update the Shenzhen office address.

Note:

1. The document will be optimized and updated from time to time. Before using this document, please make sure it is the latest version.
2. To obtain the latest document, please download it from the official website: www.rfstariot.com and www.szrfstar.com.

8 Contact Us

SHENZHEN RF-STAR TECHNOLOGY CO., LTD.

Shenzhen HQ:

Add.: C601, Skyworth Building, High-tech Park, Nanshan District, Shenzhen, Guangdong, China, 518057

Tel.: 86-755-3695 3756

Chengdu Branch:

Add.: B3-03, Building No.1, Incubation Park, High-Tech District, Chengdu, Sichuan, China, 610041

Tel.: 86-28-6577 5970

Email: sunny@szrfstar.com, sales@szrfstar.com

Web.: www.szrfstar.com

