



RF-BM-4077B2 CC2640R2F
Bluetooth 5.1 Low Energy Wireless Module
for Automotive

Version 1.0

Shenzhen RF-star Technology Co., Ltd.

May 26th, 2023

All rights reserved. Those responsible for unauthorized reproduction will be prosecuted.

1 Device Overview

1.1 Description

RF-BM-4077B2 is an RF module based on TI Bluetooth® low energy MCU of CC2640R2F-Q1 for BLE 5.1 for automotive applications. The module operates on a 32-bit ARM® Cortex®-M3 processor that runs at 48.0 MHz as the main application processor and includes the Bluetooth 4.2 low energy controller and host libraries embedded in ROM. It integrates a 24.0 MHz crystal and a 32.768 kHz crystal, 275 KB nonvolatile memory (including 128 KB in-system programmable flash), 28 KB system SRAM, an LC balun, power filter and on-board antenna. It features high performance of overall system, ultra-low power consumption, robust connection distance, rigid reliability, and up to wide temperature range of -40 °C to +105 °C, which can greatly increase the reliability and security.

1.2 Key Features

- Qualified for automotive applications
- Microcontroller
 - Powerful ARM® Cortex®-M3
 - EEMBS CoreMark® score: 142
 - Up to 48 MHz clock speed
 - 275 KB nonvolatile memory, including 128 KB in-system programmable flash
 - Up to 28 KB system SRAM, of which 20 KB is ultra-low-leakage SRAM, and 8 KB SRAM for cache or system RAM use
 - 2 pin cJTAG and JTAG debugging
 - Supports OTA upgrade
- Peripherals
 - Digital peripheral pins can be routed to 31 GPIOs
 - Four general-purpose timer modules (eight 16 bit or four 32 bit timers, PWM each)
 - 12 bit ADC, 200 ksamples/s, 8 channel analog MUX
 - Continuous time comparator
 - Ultra-low power analog comparator
 - Programmable current source
 - UART
 - 2 × SSI
 - I²C, I²S
 - Real-time clock (RTC)
- AES-128 security module
- True random number generator (TRNG)
- Support for eight capacitive sensing buttons
- Integrated temperature sensor
- RF Section
 - 2.4 GHz RF transceiver compatible with Bluetooth low energy (BLE) 5.1 specifications
 - Excellent receiver sensitivity (-97 dBm for BLE 1 Mbps), selectivity, and blocking performance
 - Programmable output power up to +5 dBm
 - Link budget of 102 dB for BLE 1 Mbps
- Low Power
 - Wide supply voltage range: 1.8 V ~ 3.8 V
 - Active-mode RX: 6.1 mA
 - Active-mode TX at 0 dBm: 7.0 mA
 - Active-mode TX at +5 dBm: 9.3 mA
 - Active-mode MCU: 61 μA/MHz
 - Active-mode MCU: 48.5 CoreMark/mA
 - Active-mode sensor controller: 0.4 mA + 8.2 μA/MHz
 - Standby: 1.3 μA (RTC running and RAM/CPU Retention)
 - Shutdown: 150 nA (wake up on external events)

1.3 Applications

- Car access
- Keyless entry
- Passive entry / passive start (PEPS) systems
- Remote keyless entry (RKE)
- Car sharing
- Piloted parking
- Wireless onboard diagnostics (OBD)
- Cable replacement
- Remote control sensors
- Logistics
- Production and manufacturing automation
- Asset tracking and management
- HMI and remote display
- Access control

1.4 Functional Block Diagram

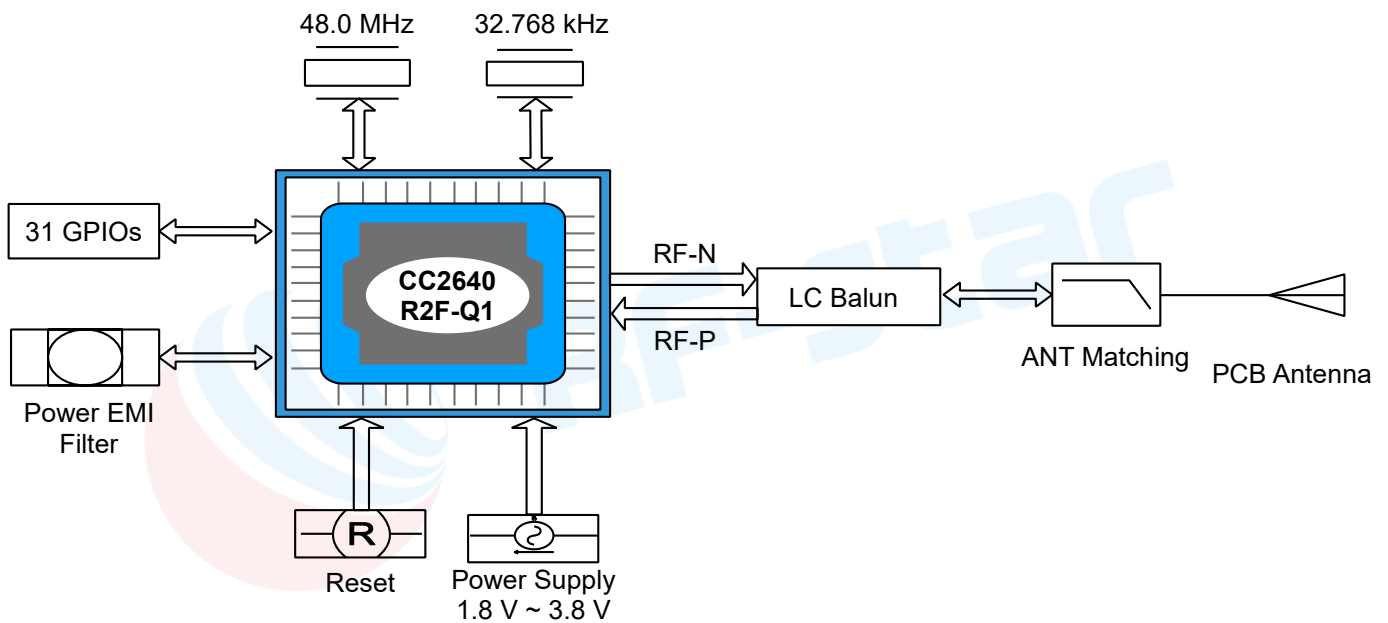

Figure 1. Functional Block Diagram of RF-BM-4077B2

1.5 Part Number Conventions

The part numbers are of the form of RF-BM-4077B2 where the fields are defined as follows:

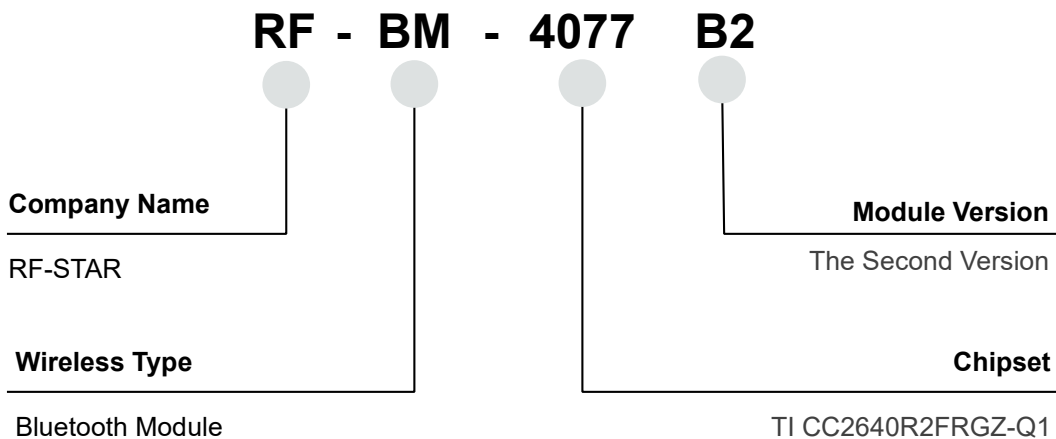

Figure 2. Part Number Conventions of RF-BM-4077B2

Table of Contents

1 Device Overview	2
1.1 Description.....	2
1.2 Key Features	2
1.3 Applications.....	3
1.4 Functional Block Diagram	3
1.5 Part Number Conventions	3
Table of Contents.....	4
2 Module Configuration and Functions	5
2.1 Module Parameters.....	5
2.2 Module Pin Diagram	6
2.3 Pin Functions.....	6
3 Specifications	8
3.1 Recommended Operating Conditions	8
3.2 Handling Ratings.....	8
4 Application, Implementation, and Layout.....	9
4.1 Module Photos	9
4.2 Recommended PCB Footprint.....	9
4.3 Schematic Diagram.....	10
4.4 Reference Design	10
4.5 Antenna.....	11
4.5.1 Antenna Design Recommendation	11
4.6 Basic Operation of Hardware Design	11
4.7 Trouble Shooting.....	12
4.7.1 Unsatisfactory Transmission Distance.....	12
4.7.2 Vulnerable Module.....	13
4.7.3 High Bit Error Rate	13
4.8 Electrostatics Discharge Warnings	13
4.9 Soldering and Reflow Condition.....	13
5 Optional Package Specification	15
6 Revision History	17
7 Contact Us.....	18

2 Module Configuration and Functions

2.1 Module Parameters

Table 1. Parameters of RF-BM-4077B2

Chipset	CC2640R2F-Q1
Supply Power Voltage	1.8 V ~ 3.8 V, recommend to 3.3 V
Frequency	2402 MHz ~ 2480MHz
Maximum Transmit Power	-21 dBm ~ +5.0 dBm (typical: 0 dBm)
Receiving Sensitivity	-97 dBm
RAM	20 KB
FLASH	128 KB
GPIO	31
Power Consumption (Active-Mode)	RX current: 6.1 mA TX current: 7.0 mA @ 0 dBm 9.3 mA @ 5 dBm MCU: 61 μ A/MHz MCU: 48.5 CoreMark/mA Sensor Controller: 0.4 mA + 8.2 μ A/MHz Standby: 1.3 μ A (RTC running and RAM / CPU retention) Shutdown 150 nA (wake up on external events)
Crystal	24 MHz, 32.768 kHz
Package	SMT Packaging (1.27-mm half-hole pitch stamp stick)
Communication Interface	UART, SPI, I ² C, I ² S, ADC
Dimension	23.5 mm × 17.0 × 2.2 mm
Type of Antenna	PCB Antenna
Operating Temperature	-40 °C ~ +105 °C
Storage Temperature	-55 °C ~ +125 °C

2.2 Module Pin Diagram

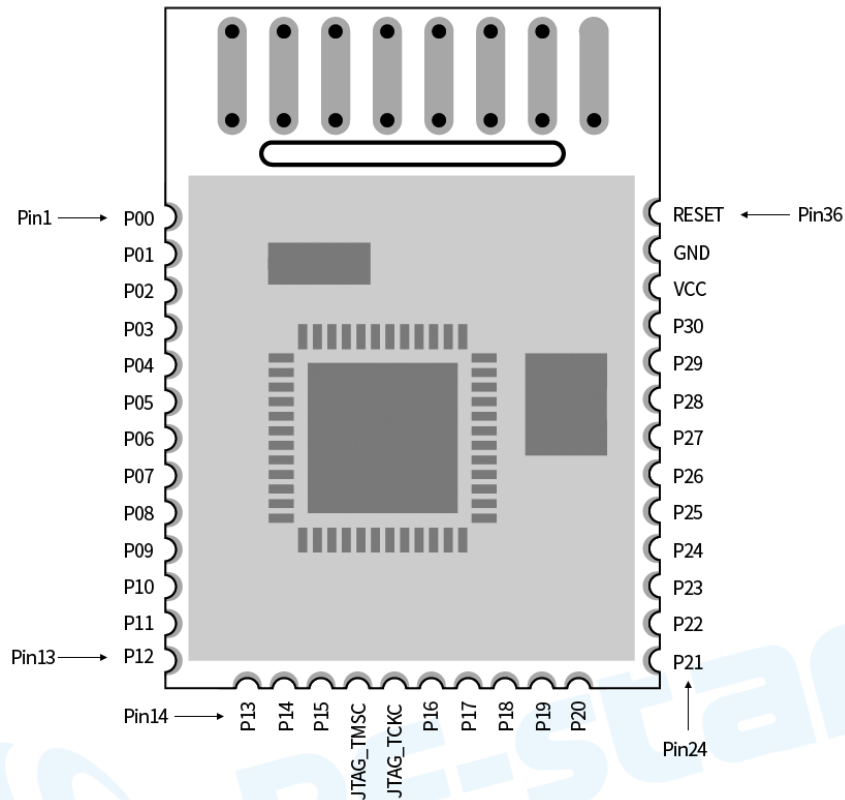

Figure 3. Pin Diagram of RF-BM-4077B2

2.3 Pin Functions

Table 2. Pin Functions of RF-BM-4077B2

Pin	Name	Chip Pin	Function	Description
1	P00	DIO_0	Digital	GPIO, Sensor Controller
2	P01	DIO_1	Digital	GPIO, Sensor Controller
3	P02	DIO_2	Digital	GPIO, Sensor Controller
4	P03	DIO_3	Digital	GPIO, Sensor Controller
5	P04	DIO_4	Digital	GPIO, Sensor Controller
6	P05	DIO_5	Digital	GPIO, Sensor Controller, high-drive capability
7	P06	DIO_6	Digital	GPIO, Sensor Controller, high-drive capability
8	P07	DIO_7	Digital	GPIO, Sensor Controller, high-drive capability
9	P08	DIO_8	Digital	GPIO
10	P09	DIO_9	Digital	GPIO
11	P10	DIO_10	Digital	GPIO
12	P11	DIO_11	Digital	GPIO

13	P12	DIO_12	Digital	GPIO
14	P13	DIO_13	Digital	GPIO
15	P14	DIO_14	Digital	GPIO
16	P15	DIO_15	Digital	GPIO
17	JTAG_TMSC	JTAG_TMSC	Digital	JTAG TMSC, high-drive capability
18	JTAG_TCKC	JTAG_TCKC	Digital	JTAG TCKC
19	P16	DIO_16	Digital	GPIO, JTAG_TDO, high-drive capability
20	P17	DIO_17	Digital	GPIO, JTAG_TDI, high-drive capability
21	P18	DIO_18	Digital	GPIO
22	P19	DIO_19	Digital	GPIO
23	P20	DIO_20	Digital	GPIO
24	P21	DIO_21	Digital	GPIO
25	P22	DIO_22	Digital	GPIO
26	P23	DIO_23	Digital or Analog	GPIO, Sensor Controller, Analog
27	P24	DIO_24	Digital or Analog	GPIO, Sensor Controller, Analog
28	P25	DIO_25	Digital or Analog	GPIO, Sensor Controller, Analog
29	P26	DIO_26	Digital or Analog	GPIO, Sensor Controller, Analog
30	P27	DIO_27	Digital or Analog	GPIO, Sensor Controller, Analog
31	P28	DIO_28	Digital or Analog	GPIO, Sensor Controller, Analog
32	P29	DIO_29	Digital or Analog	GPIO, Sensor Controller, Analog
33	P30	DIO_30	Digital or Analog	GPIO, Sensor Controller, Analog
34	VCC	VCC		Power supply 1.8 V ~ 3.8 V, Recommend 3.3 V
35	GND	GND	Ground	Ground
36	RESET	RESET_N		Reset, active low.

3 Specifications

3.1 Recommended Operating Conditions

Functional operation does not guarantee performance beyond the limits of the conditional parameter values in the table below. Long-term work beyond this limit will affect the reliability of the module more or less.

Table 3. Recommended Operating Conditions of RF-BM-4077B2

Items	Condition	Min.	Typ.	Max.	Unit
Operating Supply Voltage	or operation in battery-powered and 3.3 V systems	1.8	3.3	3.8	V
Operating Temperature	/	-40	+25	+85	°C

3.2 Handling Ratings

Table 4. Handling Ratings of RF-BM-4077B2

Items	Condition	Min.	Typ.	Max.	Unit
Input RF Level	/			5	dBm
Storage Temperature	Tstg	-55	+25	+125	°C
Human Body Model	HBM		±2000		V
Moisture Sensitivity Level			3		
Charged Device Model (XOCS pins 46, 47)			±250		V
Charged Device Model (All Other Pins)			±500		V

4 Application, Implementation, and Layout

4.1 Module Photos

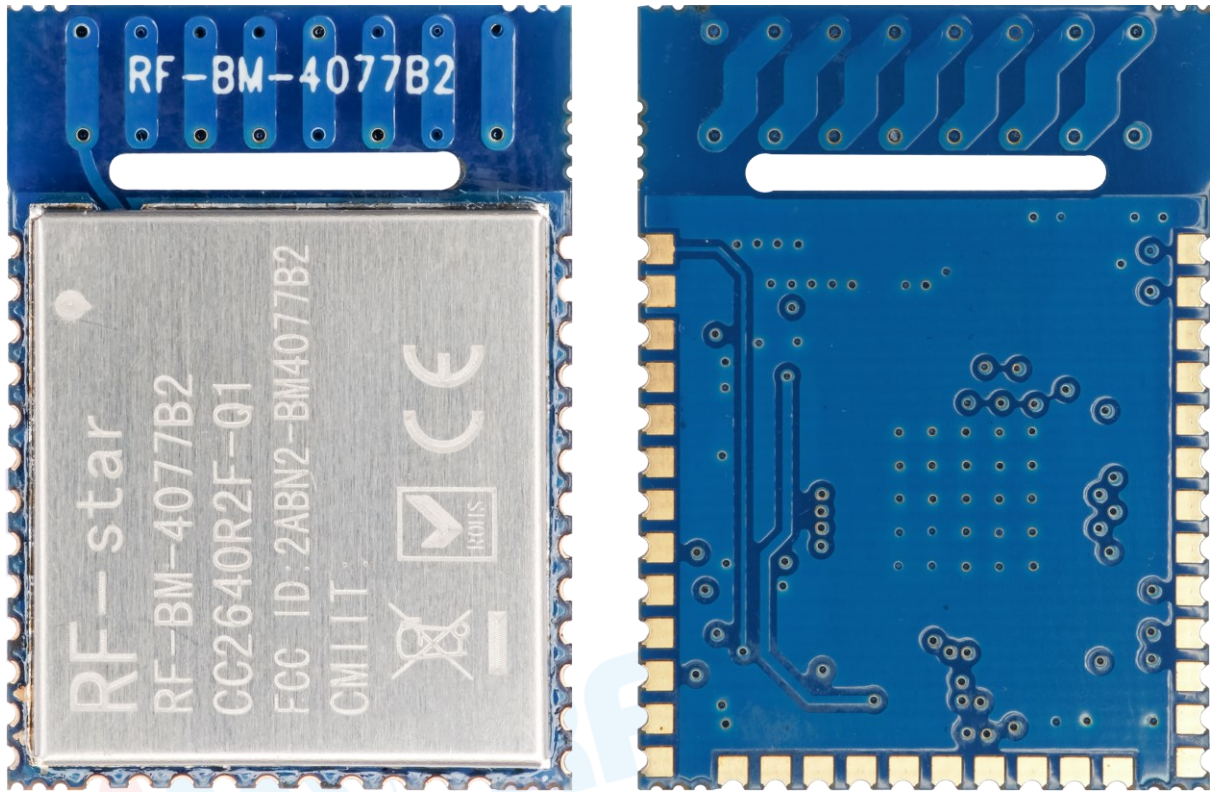

Figure 4. Photos of RF-BM-4077B2

4.2 Recommended PCB Footprint

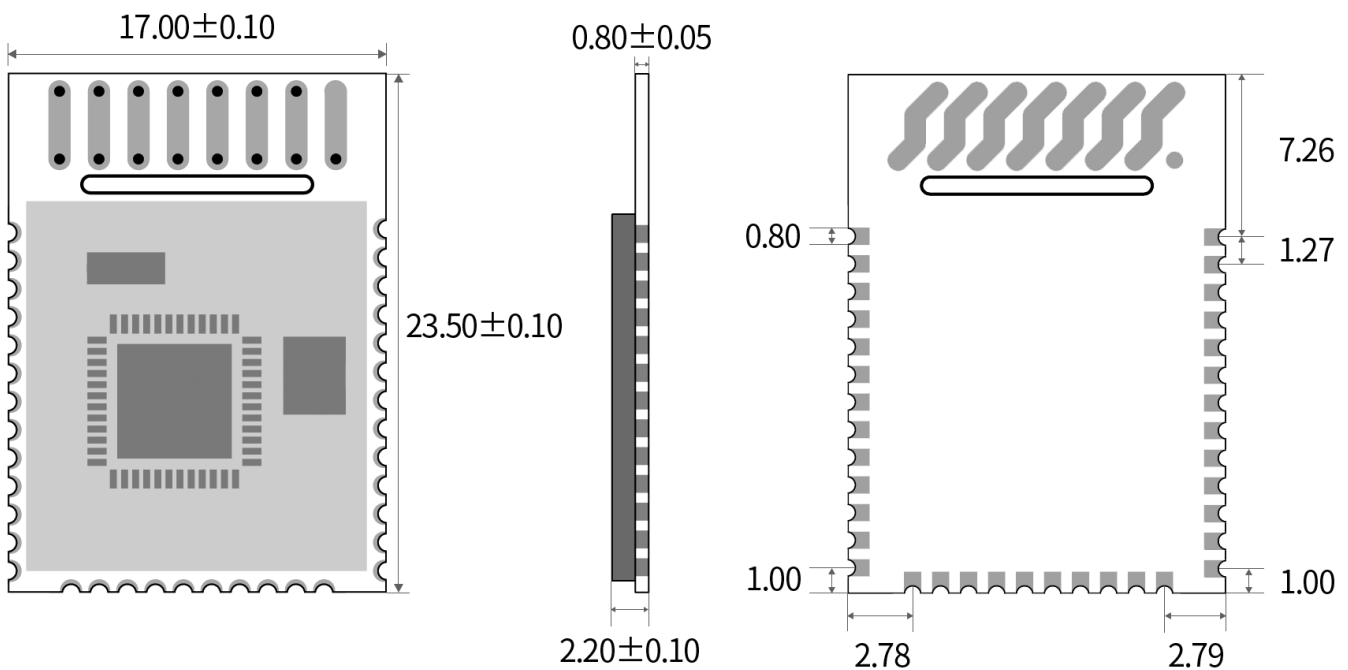

Figure 5. Recommended PCB Footprint of RF-BM-4077B2 (mm)

4.3 Schematic Diagram

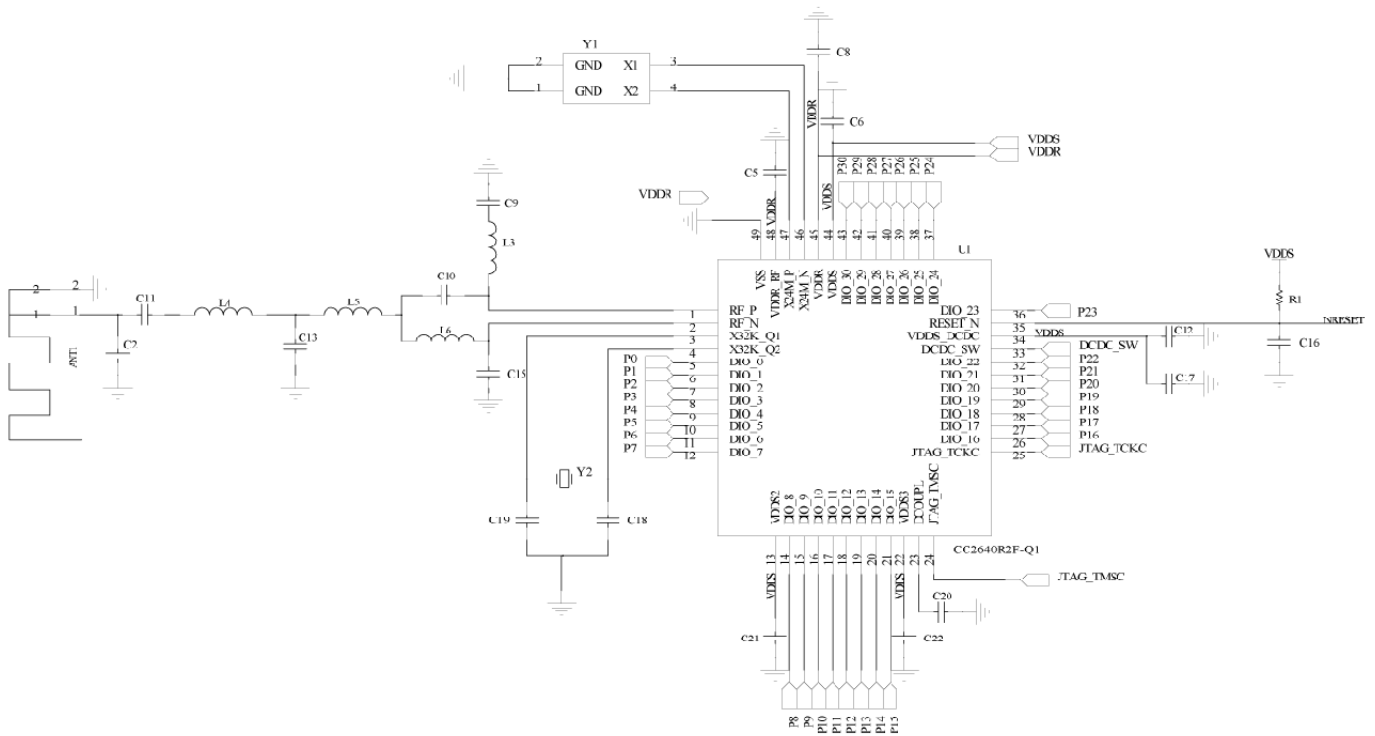
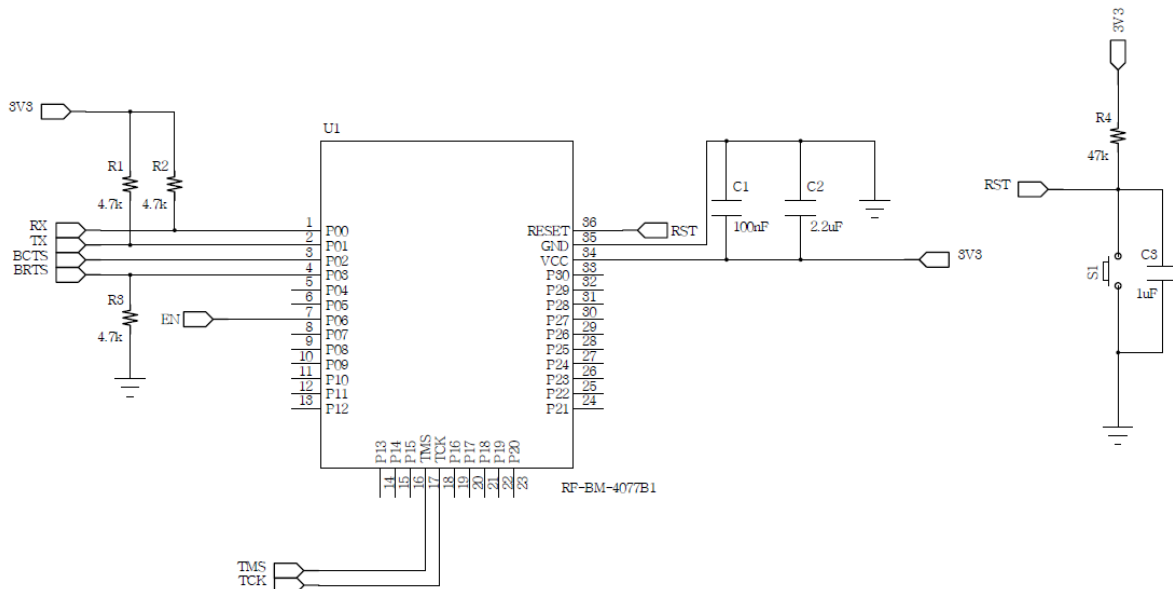

Figure 6. Schematic Diagram of RF-BM-4077B2

4.4 Reference Design



Note: EN low enable.

Figure 7. Reference Design of RF-BM-4077B2

4.5 Antenna

4.5.1 Antenna Design Recommendation

1. The antenna installation structure has a great influence on the module performance. It is necessary to ensure the antenna is exposed and preferably vertically upward. When the module is installed inside of the case, a high-quality antenna extension wire can be used to extend the antenna to the outside of the case.
2. The antenna must not be installed inside the metal case, which will cause the transmission distance to be greatly weakened.
3. The recommendation of antenna layout.

The inverted-F antenna position on PCB is free-space electromagnetic radiation. The location and layout of the antenna are key factors to increase the data rate and transmission range.

Therefore, the layout of the module antenna location and routing is recommended as follows:

- (1) Place the antenna on the edge (corner) of the PCB.
- (2) Make sure that there is no signal line or copper foil in each layer below the antenna.
- (3) It is best to hollow out the antenna position in the following figure to ensure that the S11 of the module is minimally affected.

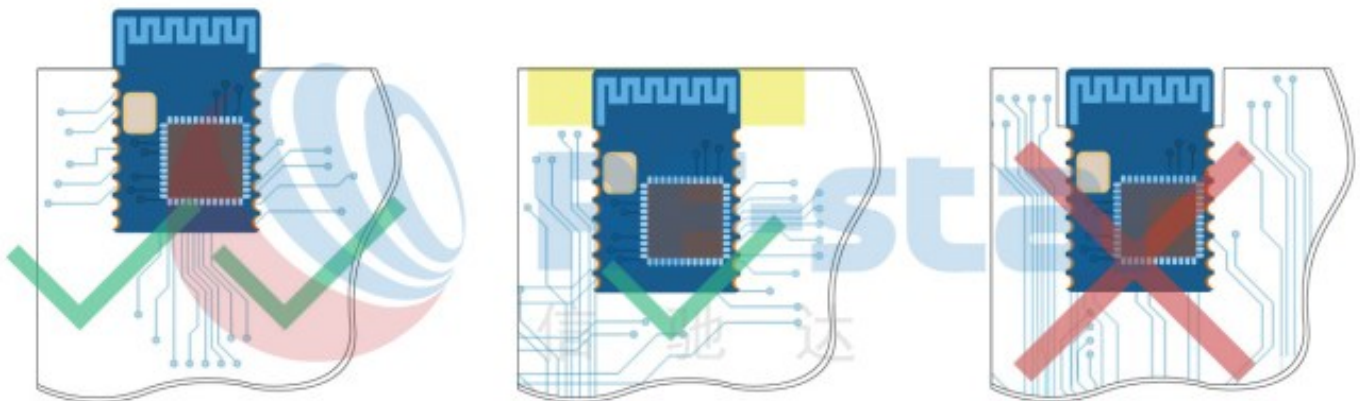

Figure 8. Recommendation of Antenna Layout

Note: The hollow-out position is based on the antenna used.

4.6 Basic Operation of Hardware Design

1. It is recommended to offer the module a DC stabilized power supply, a tiny power supply ripple coefficient, and reliable ground. Please pay attention to the correct connection between the positive and negative poles of the power supply. Otherwise, the reverse connection may cause permanent damage to the module;
2. Please ensure the supply voltage is between the recommended values. The module will be permanently damaged if the voltage exceeds the maximum value. Please ensure a stable power supply and no frequently fluctuating voltage.

3. When designing the power supply circuit for the module, it is recommended to reserve more than 30% of the margin, which is beneficial to the long-term stable operation of the whole machine. The module should be far away from the power electromagnetic, transformer, high-frequency wiring, and other parts with large electromagnetic interference.
4. The bottom of the module should avoid high-frequency digital routing, high-frequency analog routing, and power routing. If it has to route the wire on the bottom of the module, for example, it is assumed that the module is soldered to the Top Layer, the copper must be spread on the connection part of the top layer and the module, and be close to the digital part of the module and routed in the Bottom Layer (all copper is well-grounded).
5. Assuming that the module is soldered or placed in the Top Layer, it is also wrong to randomly route the Bottom Layer or other layers, which will affect the spurs and receiving sensitivity of the module to some degree;
6. Assuming that there are devices with large electromagnetic interference around the module, which will greatly affect the module performance. It is recommended to stay away from the module according to the strength of the interference. If circumstances permit, appropriate isolation and shielding can be done.
7. Assuming that there are routings of large electromagnetic interference around the module (high-frequency digital, high-frequency analog, power routings), which will also greatly affect the module performance. It is recommended to stay away from the module according to the strength of the interference. If circumstances permit, appropriate isolation and shielding can be done.
8. It is recommended to stay away from the devices whose TTL protocol is the same 2.4 GHz physical layer, for example, USB 3.0.

4.7 Trouble Shooting

4.7.1 Unsatisfactory Transmission Distance

1. When there is a linear communication obstacle, the communication distance will be correspondingly weakened. Temperature, humidity, and co-channel interference will lead to an increase in the communication packet loss rate. The performance of ground absorption and reflection of radio waves will be poor when the module is tested close to the ground.
2. Seawater has a strong ability to absorb radio waves, so the test results by the seaside are poor.
3. The signal attenuation will be very obvious if there is metal near the antenna or if the module is placed inside the metal shell.
4. The incorrect power register set or the high data rate in the open air may shorten the communication distance. The higher the data rate, the closer the distance.
5. The low voltage of the power supply is lower than the recommended value at ambient temperature, and the lower the voltage, the smaller the power is.
6. The unmatched antennas and modules or the poor quality of the antenna will affect the communication distance.

4.7.2 Vulnerable Module

1. Please ensure the supply voltage is between the recommended values. The module will be permanently damaged if the voltage exceeds the maximum value. Please ensure a stable power supply and no frequently fluctuating voltage.
2. Please ensure the anti-static installation and the electrostatic sensitivity of high-frequency devices.
3. Due to some humidity-sensitive components, please ensure suitable humidity during installation and application. If there is no special demand, it is not recommended to use at too high or too low temperature.

4.7.3 High Bit Error Rate

1. There are co-channel signal interferences nearby. It is recommended to be away from the interference sources or modify the frequency and channel to avoid interferences.
2. The unsatisfactory power supply may also cause garbled. It is necessary to ensure the power supply's reliability.
3. If the extension wire or feeder wire is of poor quality or too long, the bit error rate will be high.

4.8 Electrostatics Discharge Warnings

The module will be damaged by the discharge of static. RF-star suggests that all modules should follow the 3 precautions below:

1. According to the anti-static measures, bare hands are not allowed to touch modules.
2. Modules must be placed in anti-static areas.
3. Take the anti-static circuitry (when inputting HV or VHF) into consideration in product design.
Static may result in the degradation in performance of the module, even causing failure.

4.9 Soldering and Reflow Condition

1. Heating method: Conventional Convection or IR/convection.
2. Solder paste composition: Sn96.5/Ag3.0/Cu0.5
3. Allowable reflow soldering times: 2 times based on the following reflow soldering profile.
4. Temperature profile: Reflow soldering shall be done according to the following temperature profile.
5. Peak temperature: 245 °C.

Table 5. Temperature Table of Soldering and Reflow

Profile Feature	Sn-Pb Assembly	Pb-Free Assembly
Solder Paste	Sn63 / Pb37	Sn96.5 / Ag3.0 / Cu0.5
Min. Preheating Temperature (T_{min})	100 °C	150 °C
Max. Preheating Temperature (T_{max})	150 °C	200 °C
Preheating Time (T_{min} to T_{max}) (t_1)	60 s ~ 120 s	60 s ~ 120 s

Average Ascend Rate (T_{max} to T_p)	Max. 3 °C/s	Max. 3 °C/s
Liquid Temperature (T_L)	183 °C	217 °C
Time above Liquidus (t_L)	60 s ~ 90 s	30 s ~ 90 s
Peak Temperature (T_p)	220 °C ~ 235 °C	230 °C ~ 250 °C
Average Descend Rate (T_p to T_{max})	Max. 6 °C/s	Max. 6 °C/s
Time from 25 °C to Peak Temperature (t_2)	Max. 6 minutes	Max. 8 minutes
Time of Soldering Zone (t_p)	20±10 s	20±10 s

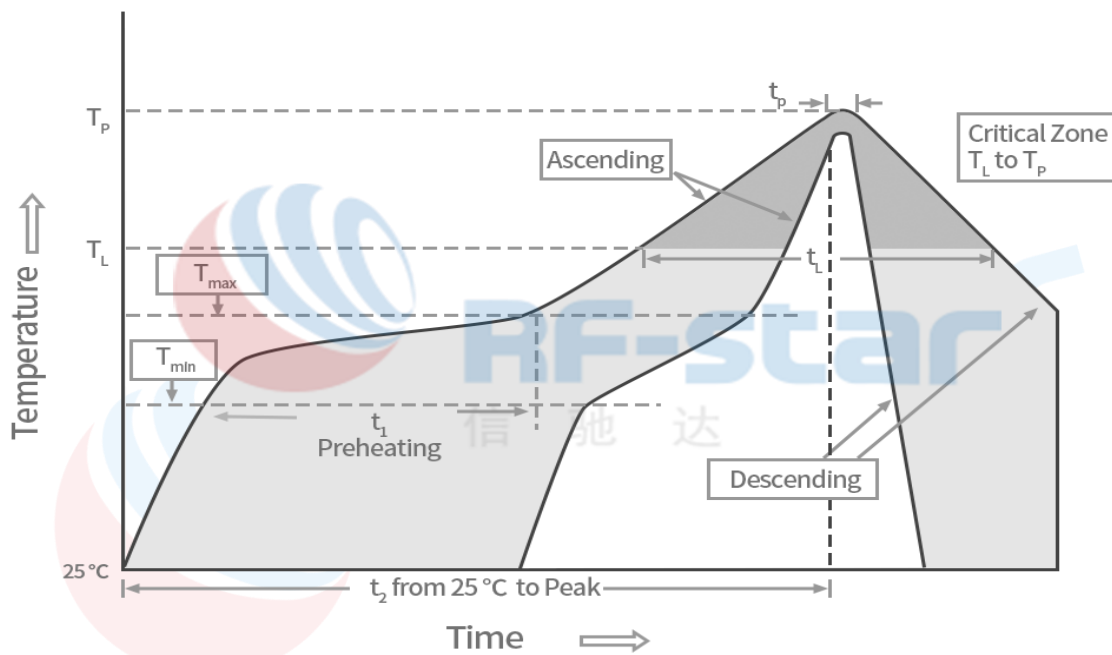

Figure 9. Recommended Reflow for Lead-Free Solder

5 Optional Package Specification

The default package method is **by tray**. If you need the modules to be shipped by tape & reel, pls contact us in advance.

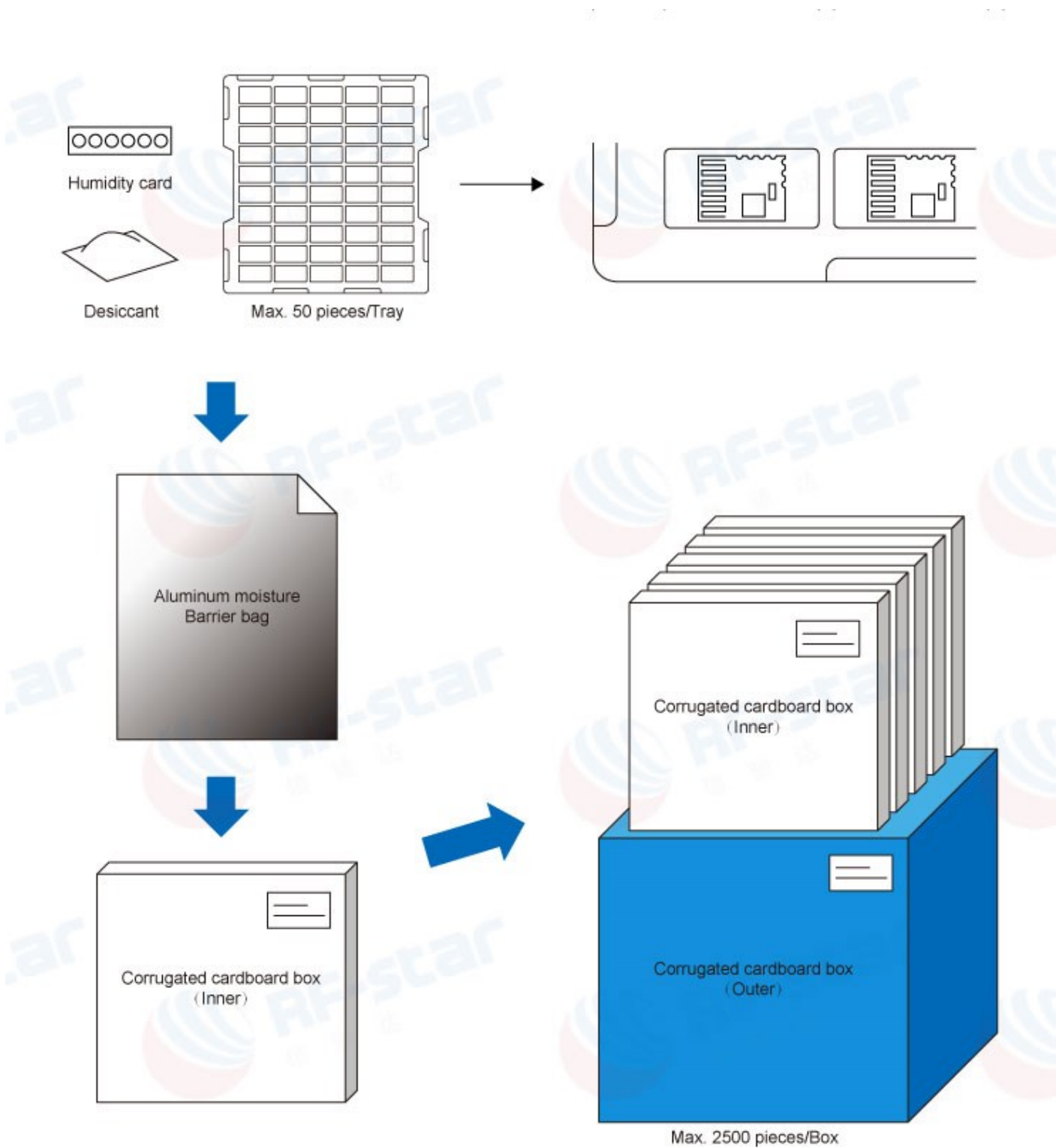

Figure 10. Default Package by Tray

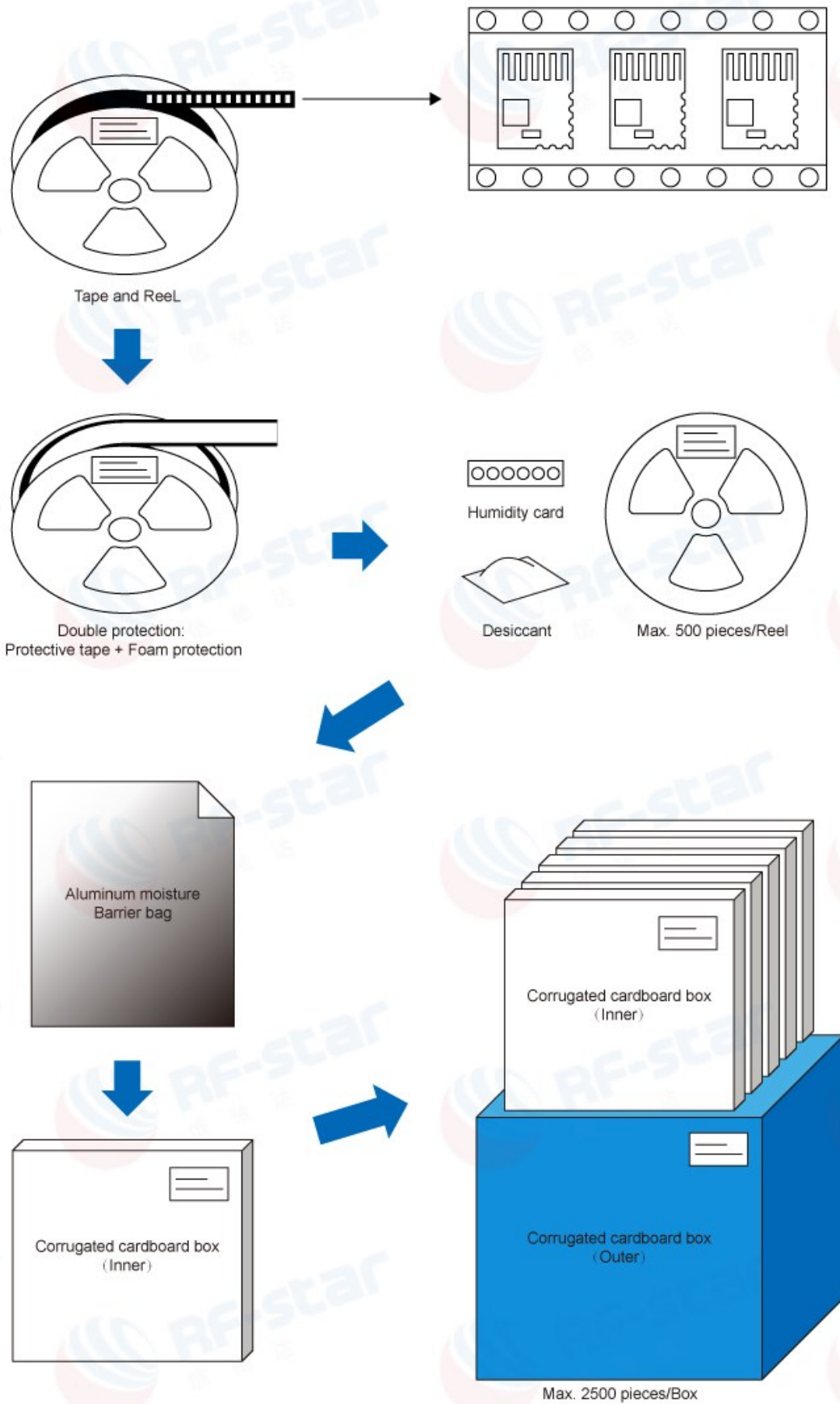

Figure 11. Package by Tape & Reel

6 Revision History

Date	Version No.	Description
2023.03.21	V1.0	The initial version is released.
2023.05.26	V1.0	Update MSL level. Update the Shenzhen office address.

Note:

1. The document will be optimized and updated from time to time. Before using this document, please make sure it is the latest version.
2. To obtain the latest document, please download it from the official website: www.rfstariot.com and www.szrfstar.com.



7 Contact Us

SHENZHEN RF-STAR TECHNOLOGY CO., LTD.

Shenzhen HQ:

Add.: Room 502, Podium Building No. 12, Shenzhen Bay Science and Technology Ecological Park, Nanshan District, Shenzhen, Guangdong, China, 518063

Tel.: 86-755-8632 9829

Chengdu Branch:

Add.: N2-1604, Global Center, North No. 1700, Tianfu Avenue, Hi-Tech District, Chengdu, Sichuan, China, 610095

Tel.: 86-28-8692 5399

Email: sunny@szrfstar.com, sales@szrfstar.com

Web.: www.rfstariot.com, www.szrfstar.com

